

Installation Guide

Zoned Damper Control



Pelican Wireless Systems, 2655 Collier Canyon Rd. Livermore, CA 94551

Phone: 888.512.0490

Email: support@pelicanwireless.com Website: www.pelicanwireless.com

Table of Contents

Damper Controller Options	3
Application and Communication	4
Thermostat Wired to Damper Actuator	8
Thermostat Terminal Designations	9
Thermostat Mounting	10
Limited Wire Installation	10
Thermostat Installation	11
Thermostat Wiring Diagrams	
Power-Open, Spring-Return Actuator	12
Power-Closed, Spring-Return Actuator	12
Power-Open, Power-Closed or Floating Actuator	13
Dual Power-Open, Spring-Return Actuators	13
Dual Power-Closed, Spring-Return Actuators	14
Dual Power-Open, Power-Closed or Floating Actuators	14
Reheat: ON/OFF or Power-Open, Spring-Return Valve Motor	15
Reheat: Power-Open, Power Closed or Floating Valve Motor	15
Wireless Damper Control and Remote Thermostat	16
TCM1 Terminal Designations	17
TCM1 Mounting	18
TCM1 Wireless Communication with Remote Thermostat	19
TCM1 Installation	20
TCM1 Wiring Diagrams	
Power-Open, Spring-Return Actuator	21
Power-Closed, Spring-Return Actuator	21
Power-Open, Power-Closed or Floating Actuator	22
Dual Power-Open, Spring-Return Actuators	22
Dual Power-Closed, Spring-Return Actuators	23
Dual Power-Open, Power-Closed or Floating Actuators	23
Reheat: ON/OFF or Power-Open, Spring-Return Valve Motor	24
Reheat: Power-Open, Power Closed or Floating Valve Motor	24
Configuration	25

Damper Controller Options

CHOOSING THE CORRECT DAMPER CONTROLLER FOR EACH ZONE...

The Pelican solution is comprised of a Pelican zone controller residing at the HVAC equipment and multiple Pelican zone damper controllers installed around the building. Communication between the zone controller to the zone damper controllers are through Pelican's self-healing wireless mesh network.

There are two zone damper control options:

In cases where wire can easily be ran or already exists between the damper actuator and thermostat, a Pelican 24VAC powered thermostat can be installed in the conditioned space and directly wired to the damper actuator. As shown in:

- Figure 1.1 – 24VAC Powered Thermostat Wired Directly to a Single Damper Actuator
- Figure 1.2 – 24VAC Powered Thermostat Wired Directly to Two Damper Actuators

Proceed to Page 8 for further information on this option.

In cases where wire is unable to be ran from the damper actuator into the conditioned space, a Pelican 24VAC damper actuator controller (TCM1) can be installed at the actuator and a Pelican Remote Wireless Sensor can be installed in the conditioned space. The TCM1 and Remote Wireless Sensor communicate wirelessly between each other. As shown in:

- Fig. 2.1 – 24VAC Damper Actuator Controller (TCM1) Wireless Communication to a Remote Thermostat for Single Damper Actuator Control
- Fig. 2.2 – 24VAC Damper Actuator Controller (TCM1) Wireless Communication to a Remote Thermostat for Two Damper Actuator Control

Proceed to Page 16 for further information on this option.

Fig. 1.1 – 24VAC Powered Thermostat Wired Directly to Single Damper Actuator

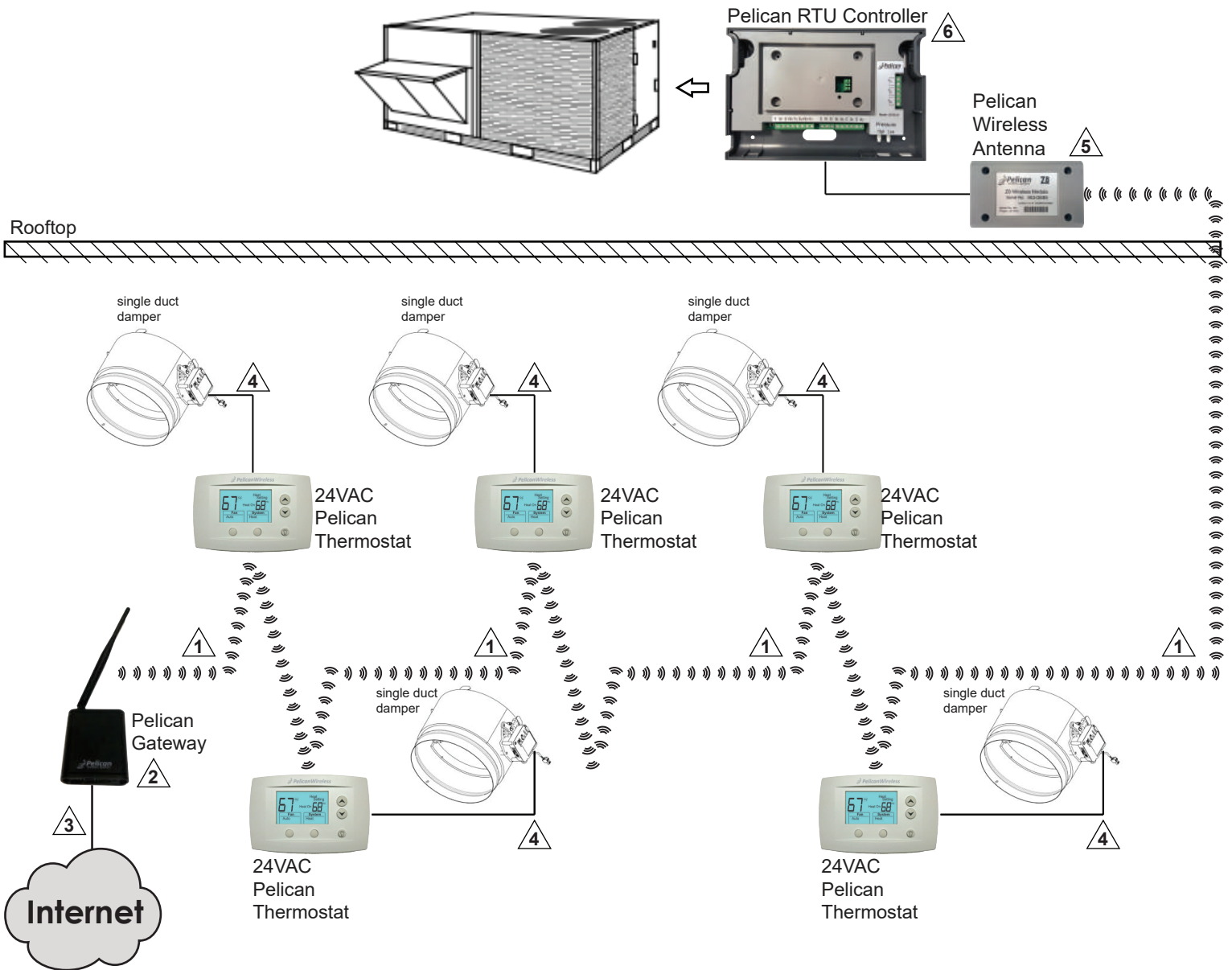

- ① COMMUNICATION ACROSS PELICAN SELF-HEALING WIRELESS MESH NETWORK (IEEE 802.15.4).
- ② ONE PELICAN GATEWAY CAN COMMUNICATE WITH UP TO 2000 PELICAN DEVICES.
- ③ HARDWIRED ETHERNET CONNECTION TO PELICAN GATEWAY.
- ④ INTERNET ENABLED THERMOSTAT IS WIRED TO ONE 24VAC ZONE ACTUATOR.

- ⑤ WIRELESS ANTENNA FROM PELICAN ZONE CONTROLLER. ANTENNA CAN BE INSTALLED ABOVE OR BELOW ROOF LINE DEPENDING ON INSTALLATION ENVIRONMENTS AND WIRELESS COMMUNICATION REQUIREMENTS.
- ⑥ PELICAN ZONE CONTROLLER. CAN BE INSTALLED ABOVE OR BELOW ROOF LINE DEPENDING ON INSTALLATION ENVIRONMENTS.

Fig. 1.2 – 24VAC Powered Thermostat Wired Directly to Two Damper Actuators

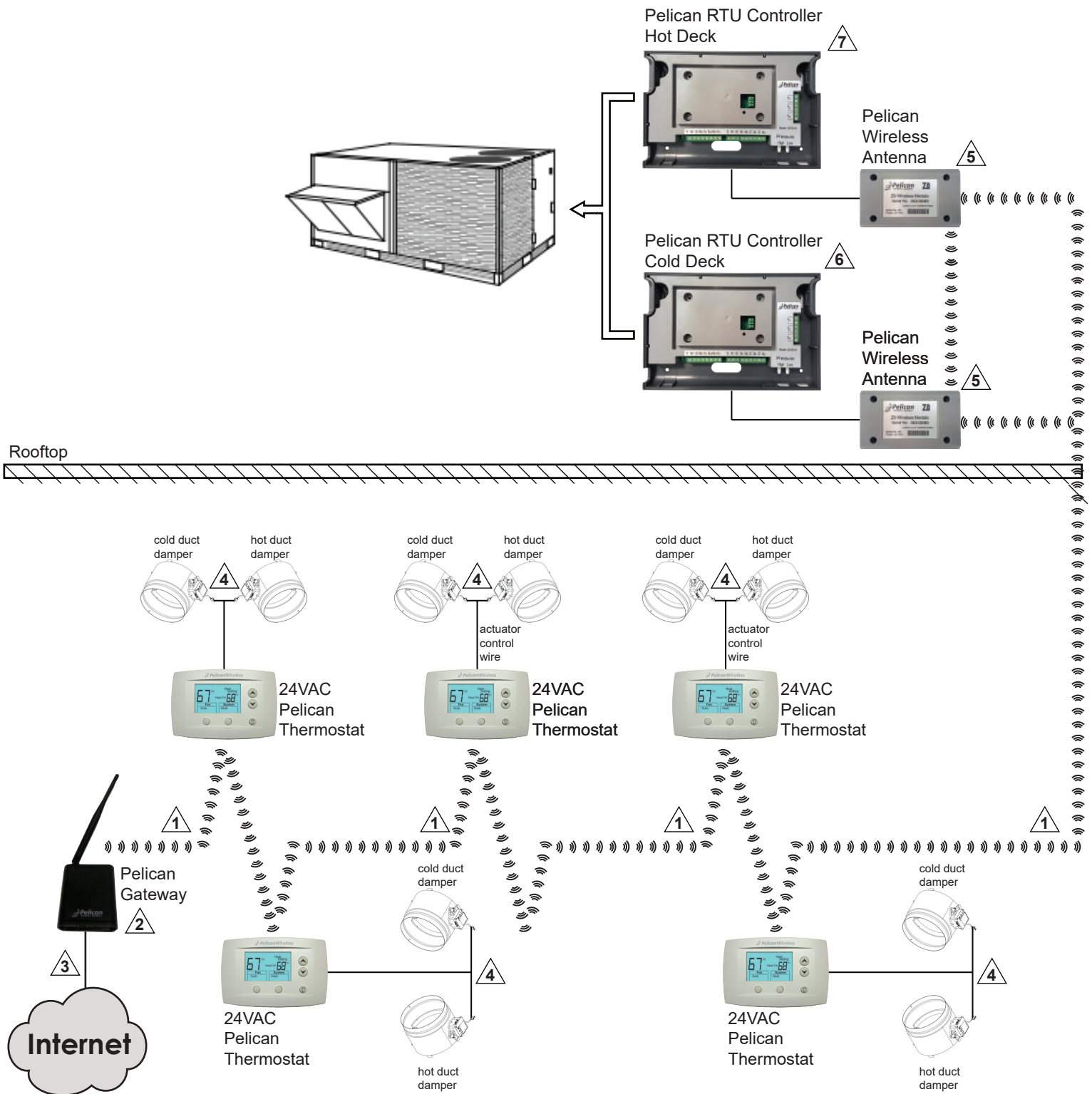

- 1 COMMUNICATION ACROSS PELICAN SELF-HEALING WIRELESS MESH NETWORK (IEEE 802.15.4).
- 2 ONE PELICAN GATEWAY CAN COMMUNICATE WITH UP TO 2000 PELICAN DEVICES.
- 3 HARDWIRED ETHERNET CONNECTION TO PELICAN GATEWAY.
- 4 INTERNET ENABLED THERMOSTAT IS WIRED TO TWO ZONE ACTUATORS.

- 5 WIRELESS ANTENNA FROM PELICAN ZONE CONTROLLER. ANTENNA CAN BE INSTALLED ABOVE OR BELOW ROOF LINE DEPENDING ON INSTALLATION ENVIRONMENTS AND WIRELESS COMMUNICATION REQUIREMENTS.
- 6 PELICAN COLD DECK ZONE CONTROLLER. CAN BE INSTALLED ABOVE OR BELOW ROOF LINE DEPENDING ON INSTALLATION ENVIRONMENTS.
- 7 PELICAN HOT DECK ZONE CONTROLLER. CAN BE INSTALLED ABOVE OR BELOW ROOF LINE DEPENDING ON INSTALLATION ENVIRONMENTS.

Fig. 2.1 – 24VAC Damper Actuator Controller (TCM1) Wireless Communication to a Remote Thermostat for Single Damper Actuator Control

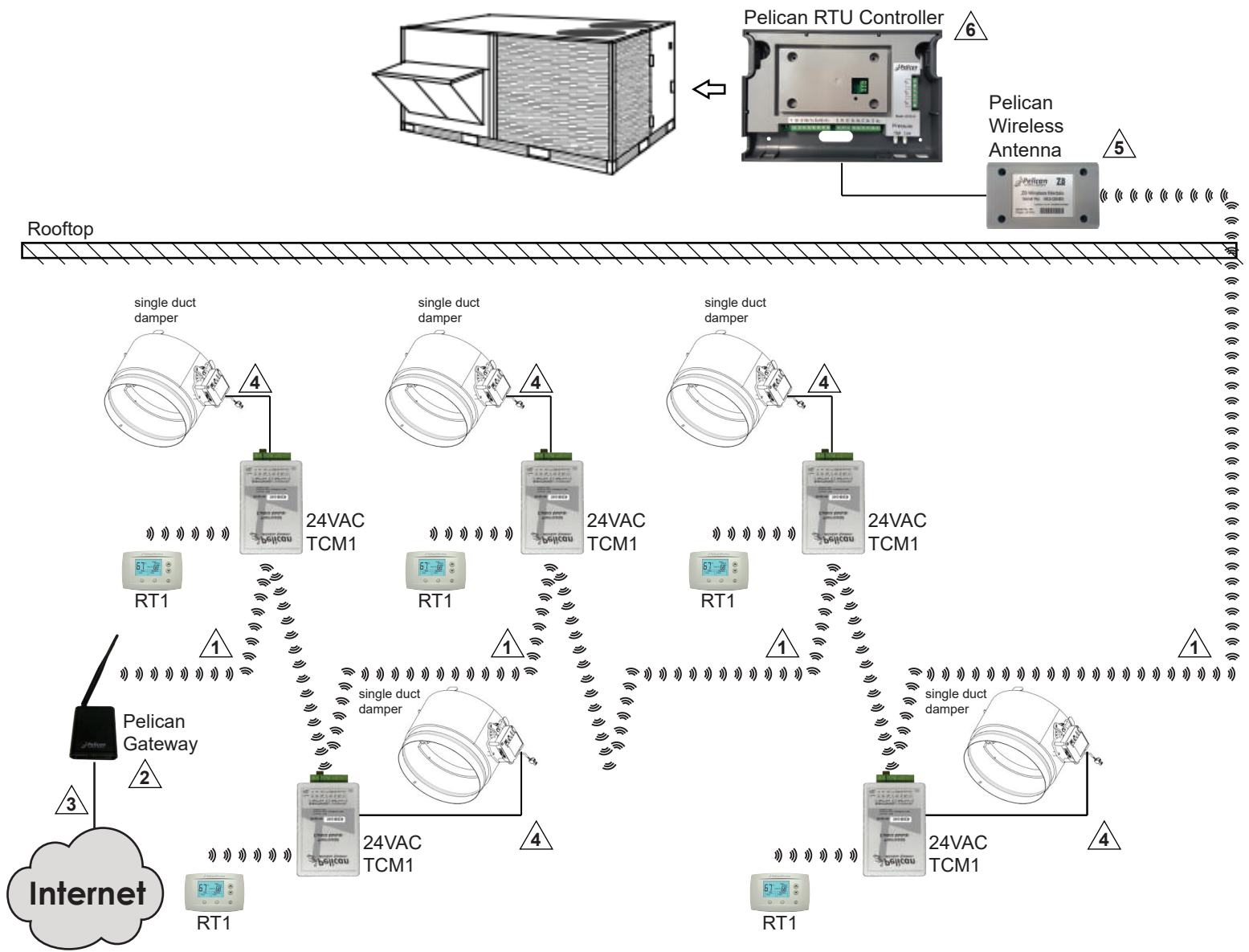

- ① COMMUNICATION ACROSS PELICAN SELF-HEALING WIRELESS MESH NETWORK (IEEE 802.15.4).
- ② ONE PELICAN GATEWAY CAN COMMUNICATE WITH UP TO 2000 PELICAN DEVICES.
- ③ HARDWIRED ETHERNET CONNECTION TO PELICAN GATEWAY.
- ④ INTERNET ENABLED TCM1 IS WIRED TO ONE ZONE ACTUATOR. RT1 REMOTE SENSOR COMMUNICATES TO TCM1 THROUGH WIRELESS MESH NETWORK.

- ⑤ WIRELESS ANTENNA FROM PELICAN ZONE CONTROLLER. ANTENNA CAN BE INSTALLED ABOVE OR BELOW ROOF LINE DEPENDING ON INSTALLATION ENVIRONMENTS AND WIRELESS COMMUNICATION REQUIREMENTS.
- ⑥ PELICAN ZONE CONTROLLER. CAN BE INSTALLED ABOVE OR BELOW ROOF LINE DEPENDING ON INSTALLATION ENVIRONMENTS.

Fig. 2.2 – 24VAC Damper Actuator Controller (TCM1) Wireless Communication to a Remote Thermostat for Two Damper Actuator Control

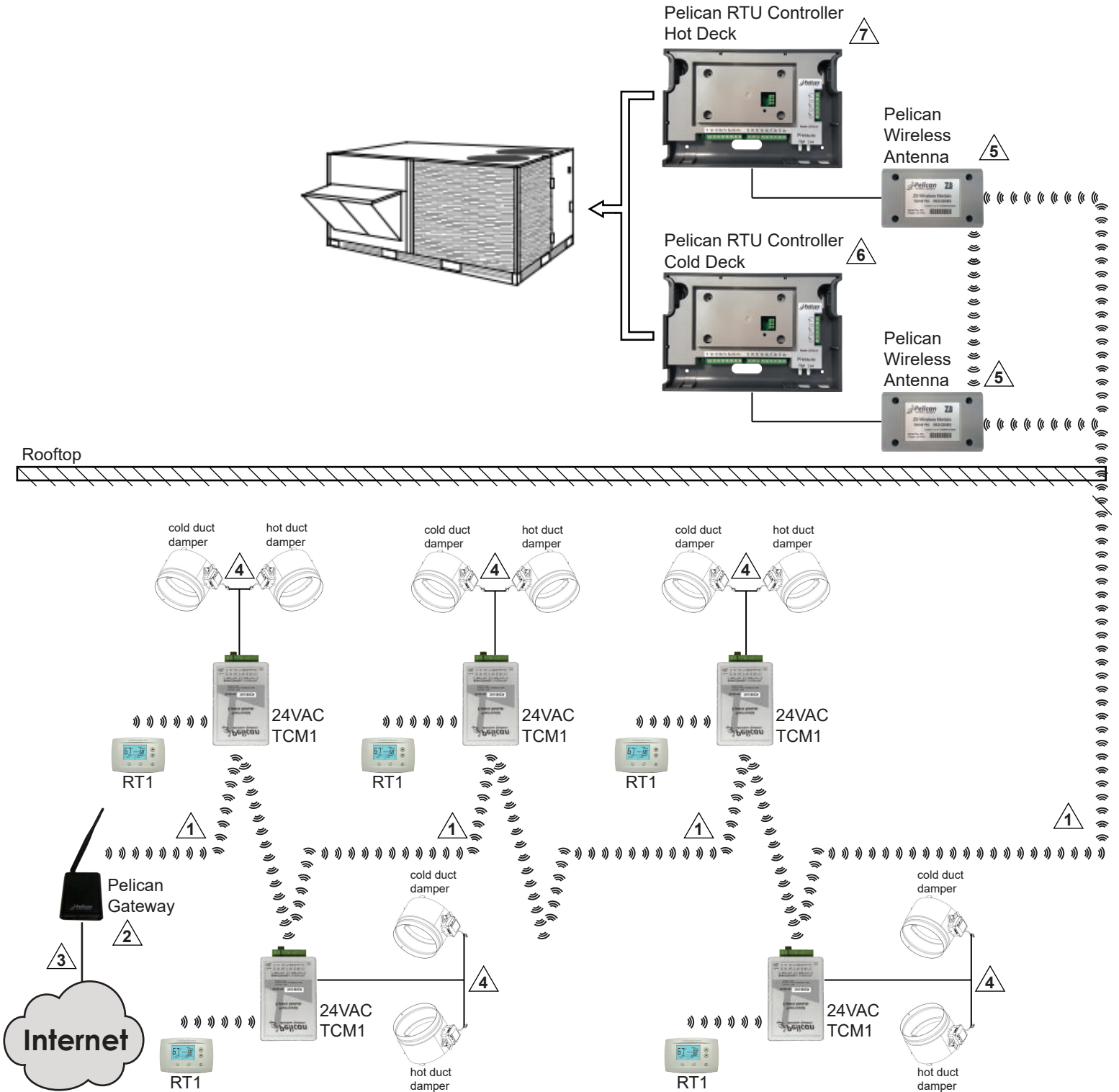

- 1 COMMUNICATION ACROSS PELICAN SELF-HEALING WIRELESS MESH NETWORK (IEEE 802.15.4).
- 2 ONE PELICAN GATEWAY CAN COMMUNICATE WITH UP TO 2000 PELICAN DEVICES.
- 3 HARDWIRED ETHERNET CONNECTION TO PELICAN GATEWAY.
- 4 INTERNET ENABLED TCM1 IS WIRED TO TWO ZONE ACTUATORS. RT1 REMOTE SENSOR COMMUNICATES TO TCM1 THROUGH WIRELESS MESH NETWORK.

- 5 WIRELESS ANTENNA FROM PELICAN ZONE CONTROLLER. ANTENNA CAN BE INSTALLED ABOVE OR BELOW ROOF LINE DEPENDING ON INSTALLATION ENVIRONMENTS AND WIRELESS COMMUNICATION REQUIREMENTS.
- 6 PELICAN COLD DECK ZONE CONTROLLER. CAN BE INSTALLED ABOVE OR BELOW ROOF LINE DEPENDING ON INSTALLATION ENVIRONMENTS.
- 7 PELICAN HOT DECK ZONE CONTROLLER. CAN BE INSTALLED ABOVE OR BELOW ROOF LINE DEPENDING ON INSTALLATION ENVIRONMENTS.



Thermostat Wired to Damper Actuator

WHEN INSTALLING THIS PRODUCT...

1. Read these instructions carefully and thoroughly. Failure to follow these instructions or a result of improper installation, service, adjustments, maintenance, and/or use can result in personal injury, damage to personal property, and/or cause a hazardous and dangerous situation.
2. Check the ratings and description given in the specification of the product to make sure the product is suitable for your application
3. Installer must be trained and experienced service technician. Follow all safety codes and regulations and all local and state building codes. Read instructions thoroughly and follow any warnings or notes.
4. After installation is complete, check product operation as provided in these instructions.

CAUTION

-
1. Disconnect power supply before connecting any wiring to device to prevent electrical shock or damage to equipment.
 2. This guide is designed for certified, trained, and experienced service technicians. Failure to follow installation instructions does not alleviate installer responsibility to protect the equipment, the property, and the device it is being connected too. If at anytime if there is concern or confusion about how to install this device, immediately stop what you are doing and either contact Pelican Wireless Systems or a certified Pelican Wireless Systems distributor.
-

WARNING

-
1. This equipment is designed to communicate over radio frequency to other Pelican equipment only. If this equipment is not installed and used in accordance with the instruction manual, you may experience wireless interference. This device has been tested and complies with FCC rules and regulations.
-

LOCATION AND MOUNTING

Choose a location for the Pelican zone thermostat that represents that spaces temperature, and where connections are accessible. The zone thermostat is directly wired to the damper actuator.

Fig. 3.1 – Pelican 24 VAC Thermostat Terminal Designations

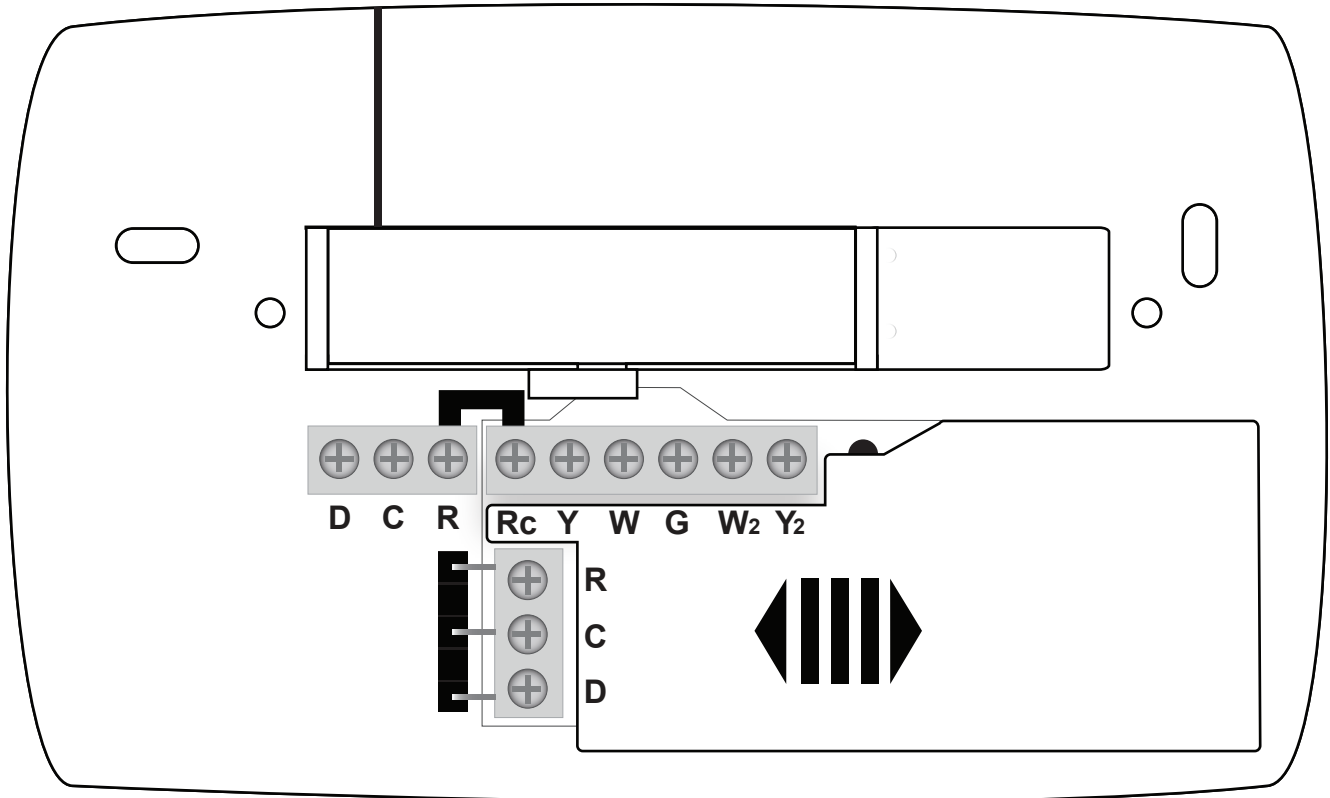

SINGLE DUCT

C	Common 24VAC
R	24VAC Power
Y	24VAC Damper Power Open
Y2	24VAC Damper Power Close
W	24VAC Reheat Power Open or On
W2	24VAC Reheat Power Close

DUAL DUCT

C	Common 24VAC
R	24VAC Power
Y	24VAC Cold Damper Power Open
Y2	24VAC Cold Damper Power Close
W	24VAC Heat Damper Power Open
W2	24VAC Heat Damper Power Close

Fig. 3.2 – Pelican 24 VAC Thermostat Mounting

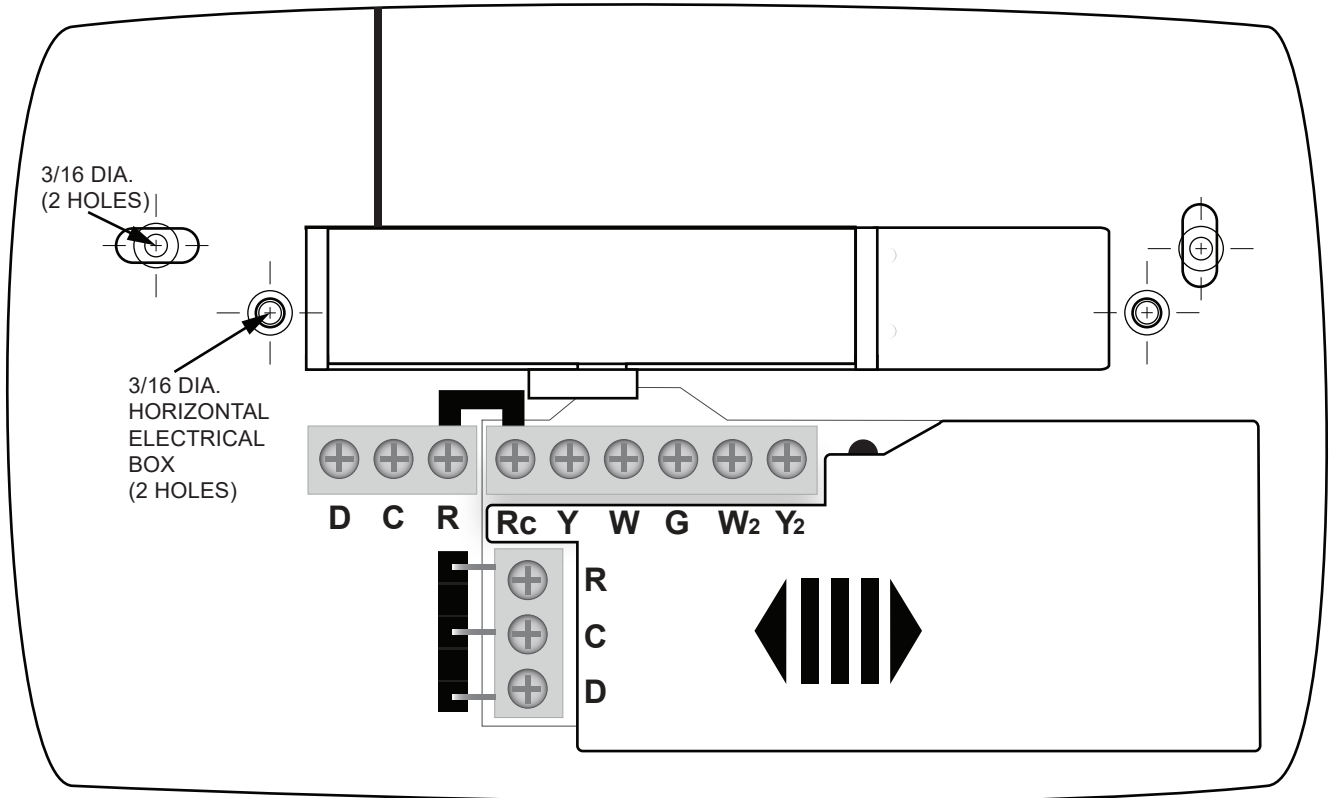

Mounting

Included in the Pelican thermostat kit are two sets of mounting screws. Choose the correct screw and mounting holes for the location the thermostat is being installed.

LIMITED THREE WIRE OPTION (only if required)

In cases where there is limited wiring between the damper actuator and thermostat, the WM500 Wiring Module can be removed from the Pelican thermostat. The WM500 can be placed at the damper actuator and wired to the thermostat with a maximum of 500 feet of standard unshielded thermostat wires.

1. Remove the wire module (WM500) from the thermostat base

Loosen the R and Rc terminals to remove the jumper. Loosen R, C, D terminals on WM500. Gently slide WM500 to the right to remove.

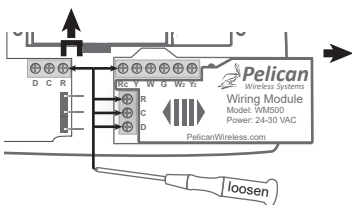

2. Mount WM500 next to damper actuator.

Connect WM500 to Damper Actuator following same wiring control diagrams found in Thermostat Detail Wiring Guide (Pg. 12-15) of this document. 24VAC power needs to be supplied to both the WM500, Pelican Thermostat, and Damper Actuator.

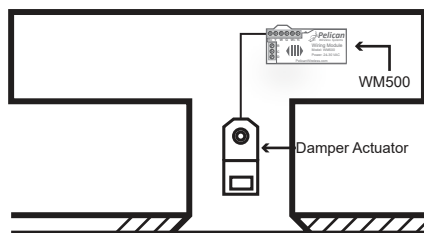

3. Connect R, C, D communication wire from WM500 to Pelican Thermostat.

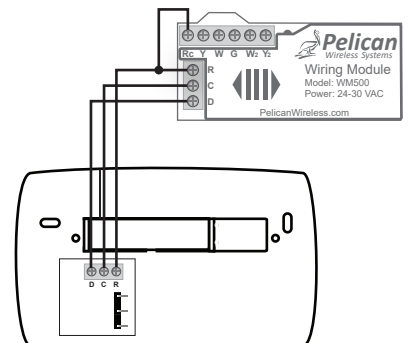

INSTALLATION

1. Remove the thermostat's cover by gently pulling the thermostat faceplate away from the back plate.
2. Place the thermostat back plate on a flat surface for mounting. Mark mounting holes and drill 3/16" holes into mounting surface. Note the wiring channel.
3. Thermostat wiring diagrams are shown in the Thermostat Detail Wiring Diagram section as follows:
 - a. Page 12 - Fig. 4 Single Duct: Power-Open / Spring-Return Damper Actuator
 - b. Page 12 - Fig. 5 Single Duct: Power-Closed / Spring-Return Damper Actuator
 - c. Page 13 - Fig. 6 Single Duct: Power-Open / Power-Closed or Floating Damper Actuator
 - d. Page 13 - Fig. 7 Dual Duct: Power-Open / Spring-Return Damper Actuators
 - e. Page 14 - Fig. 8 Dual Duct: Power-Closed / Spring-Return Damper Actuators
 - f. Page 14 - Fig. 9 Dual Duct: Power-Open / Power-Closed or Floating Damper Actuators
 - g. Page 15 - Fig. 10 Reheat: ON/OFF Electric or Power-Open / Spring-Return Valve Motor
 - h. Page 15 - Fig. 11 Reheat: Power-Open / Power-Closed or Floating Valve Motor



WARNING

The following thermostat wiring diagrams are to be used as reference to the most common application where a Pelican thermostat will be installed to control specific damper actuators. For dual ducted applications, a single Pelican thermostat will control both the hot and cold damper actuators for the zone. In the case the system you are connecting the Pelican thermostat to is not defined in this installation guide. Contact Pelican Technical Support for assistance at 888-512-0490 or email support@pelicanwireless.com.



Thermostat Detail Wiring Diagrams

Fig. 4 – Single Duct: Power-Open / Spring-Return Damper Actuator

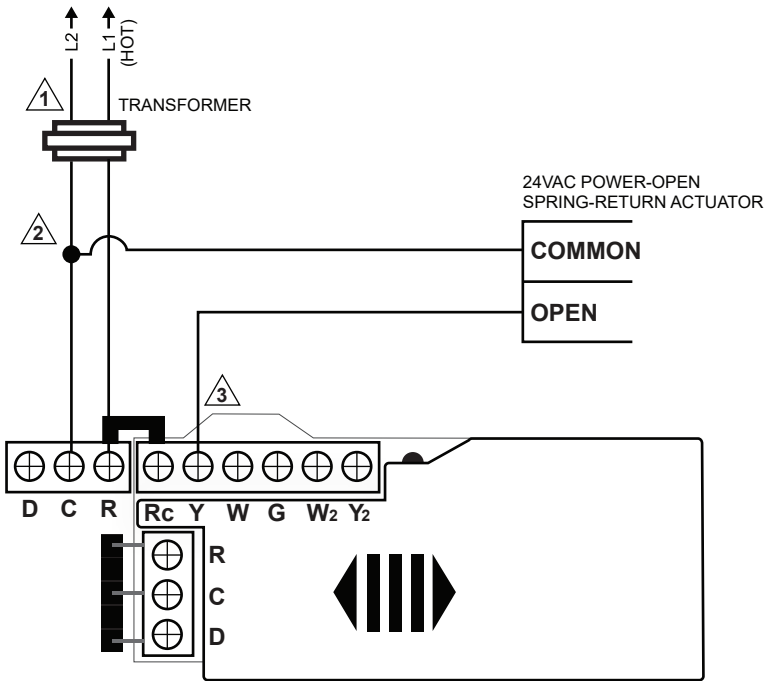

- 1 POWER SUPPLY. PROVIDE DISCONNECT MEANS AND OVERLOAD PROTECTION AS REQUIRED.
- 2 POWER TO EQUIPMENT 24VAC. SIZE TRANSFORMERS AS NEEDED.
- 3 OUTPUT IS 24VAC @ 1A. PROVIDE PROPERLY SIZED RELAYS AS NEEDED.

Fig. 5 – Single Duct: Power-Closed / Spring-Return Damper Actuator

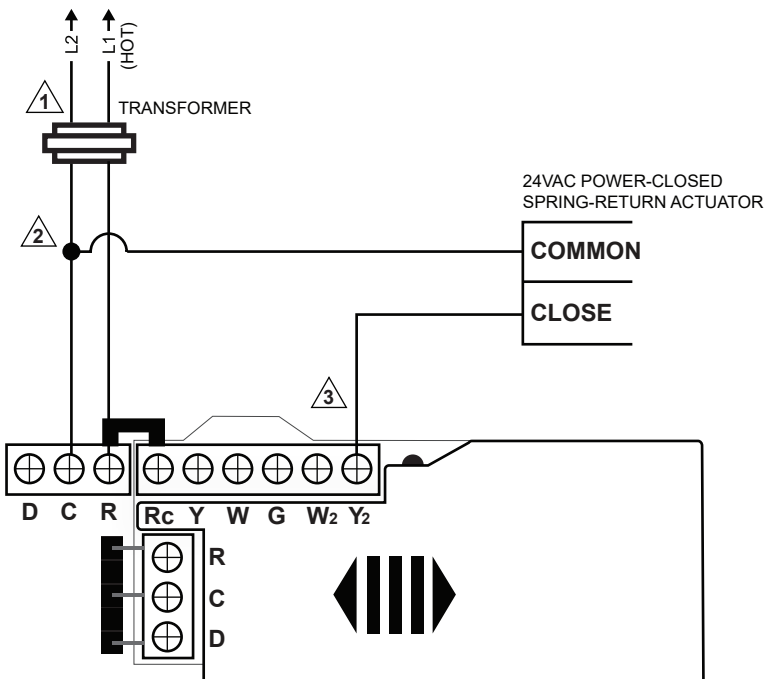

- 1 POWER SUPPLY. PROVIDE DISCONNECT MEANS AND OVERLOAD PROTECTION AS REQUIRED.
- 2 POWER TO EQUIPMENT 24VAC. SIZE TRANSFORMERS AS NEEDED.
- 3 OUTPUT IS 24VAC @ 1A. PROVIDE PROPERLY SIZED RELAYS AS NEEDED.

Fig. 6 – Single Duct: Power-Open / Power-Closed or Floating Damper Actuator

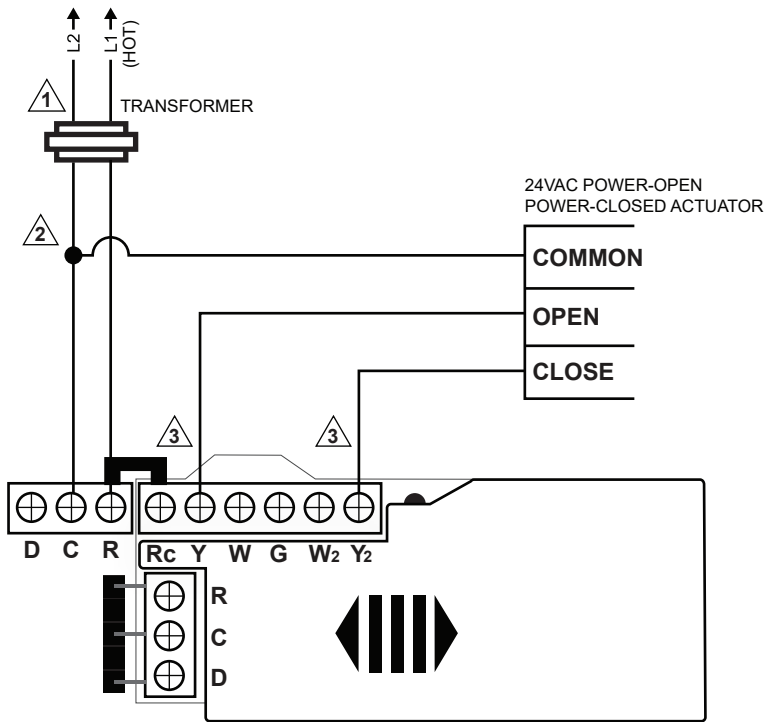

- ⚠ FOR LIMITED WIRE INSTALLATIONS REFERENCE PAGE 10 OF THIS INSTALL GUIDE.
- 1 POWER SUPPLY. PROVIDE DISCONNECT MEANS AND OVERLOAD PROTECTION AS REQUIRED.
- 2 POWER TO EQUIPMENT 24VAC. SIZE TRANSFORMERS AS NEEDED.
- 3 OUTPUT IS 24VAC @ 1A. PROVIDE PROPERLY SIZED RELAYS AS NEEDED.

Fig. 7 – Dual Duct: Power-Open / Spring-Return Damper Actuators

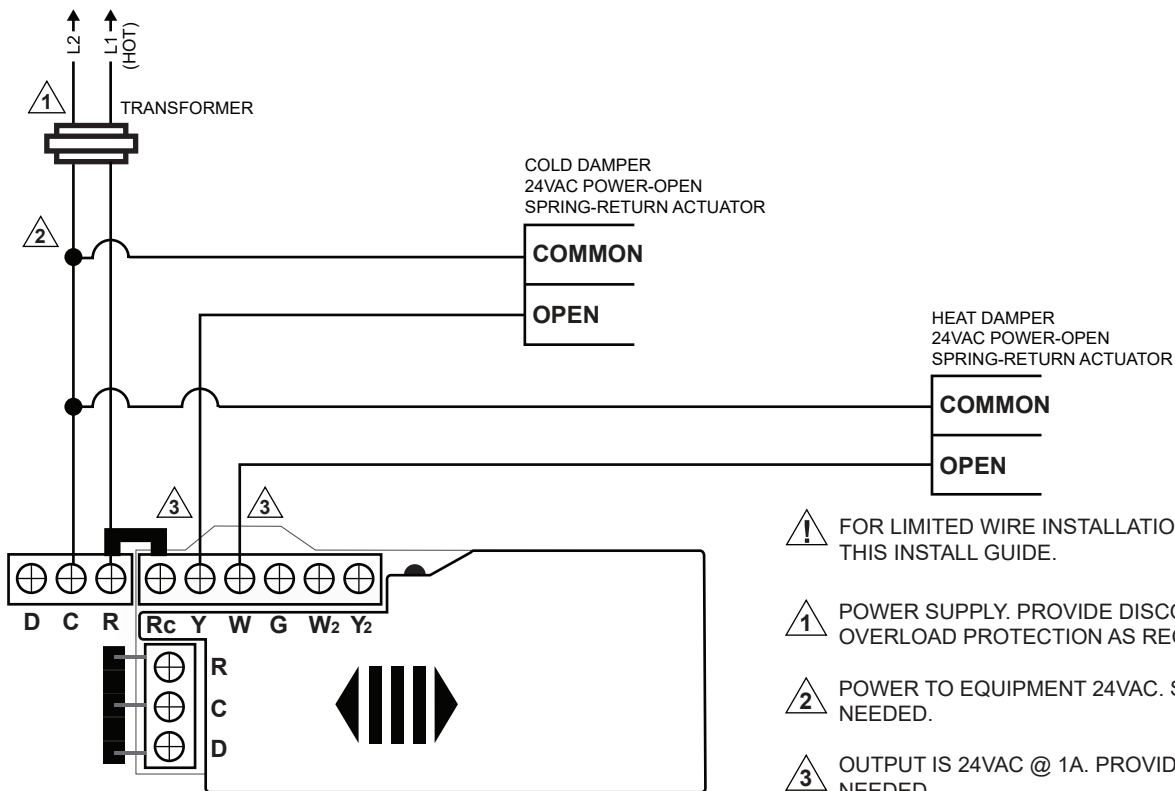

- ⚠ FOR LIMITED WIRE INSTALLATIONS REFERENCE PAGE 10 OF THIS INSTALL GUIDE.
- 1 POWER SUPPLY. PROVIDE DISCONNECT MEANS AND OVERLOAD PROTECTION AS REQUIRED.
- 2 POWER TO EQUIPMENT 24VAC. SIZE TRANSFORMERS AS NEEDED.
- 3 OUTPUT IS 24VAC @ 1A. PROVIDE PROPERLY SIZED RELAYS AS NEEDED.

Fig. 8 – Dual Duct: Power-Closed / Spring-Return Damper Actuators

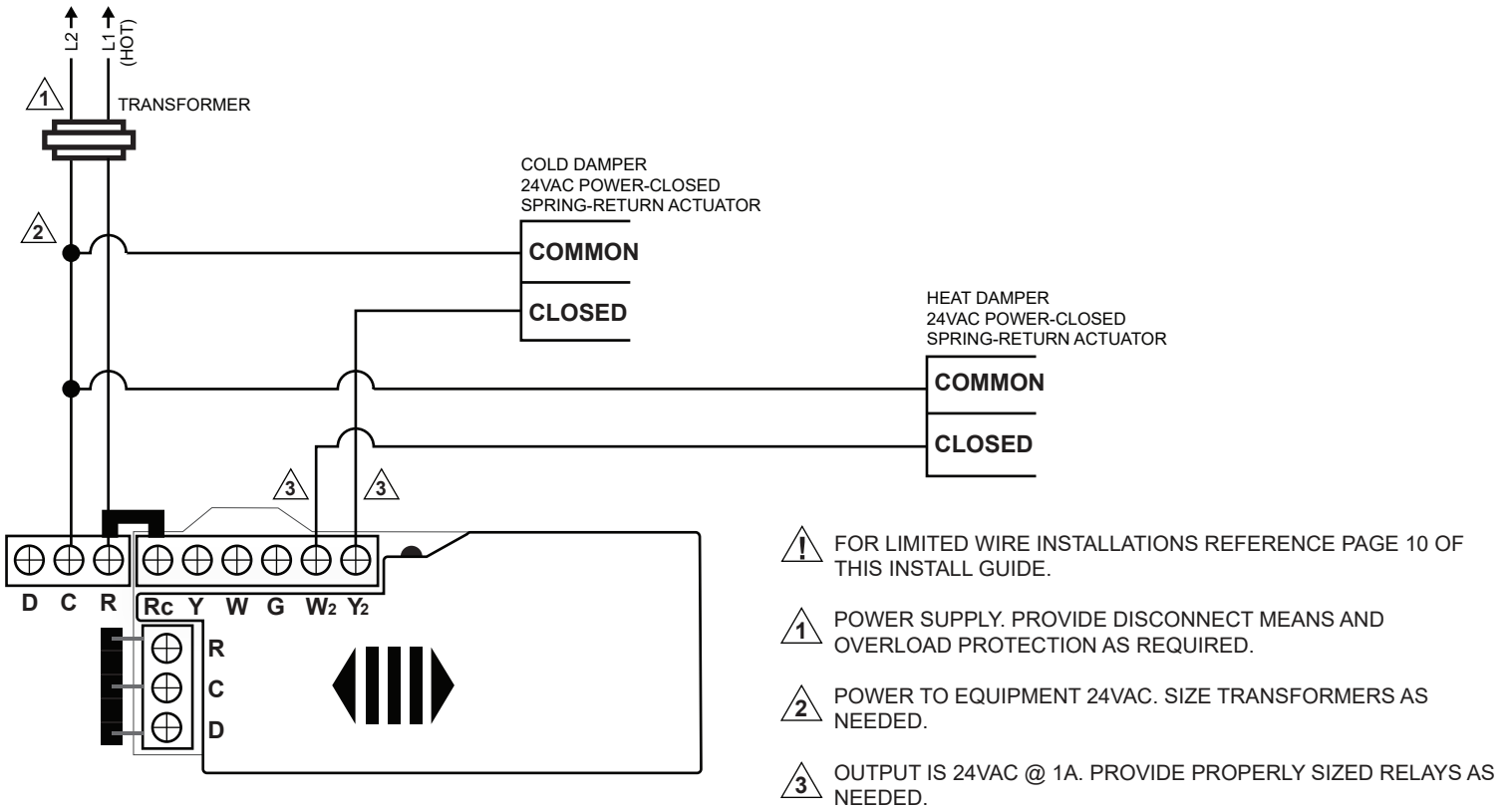

Fig. 9 – Dual Duct: Power-Open / Power-Closed or Floating Damper Actuators

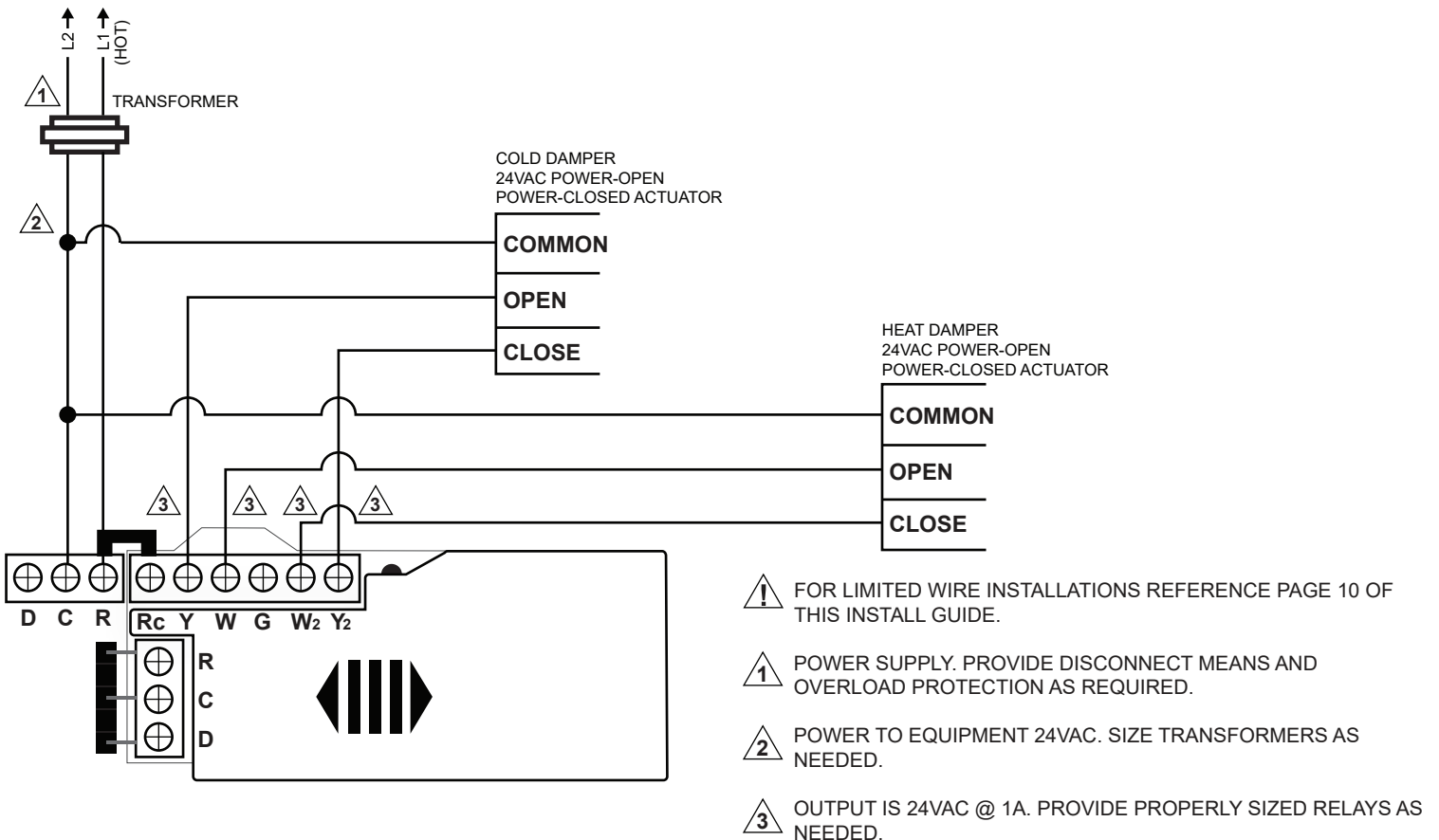
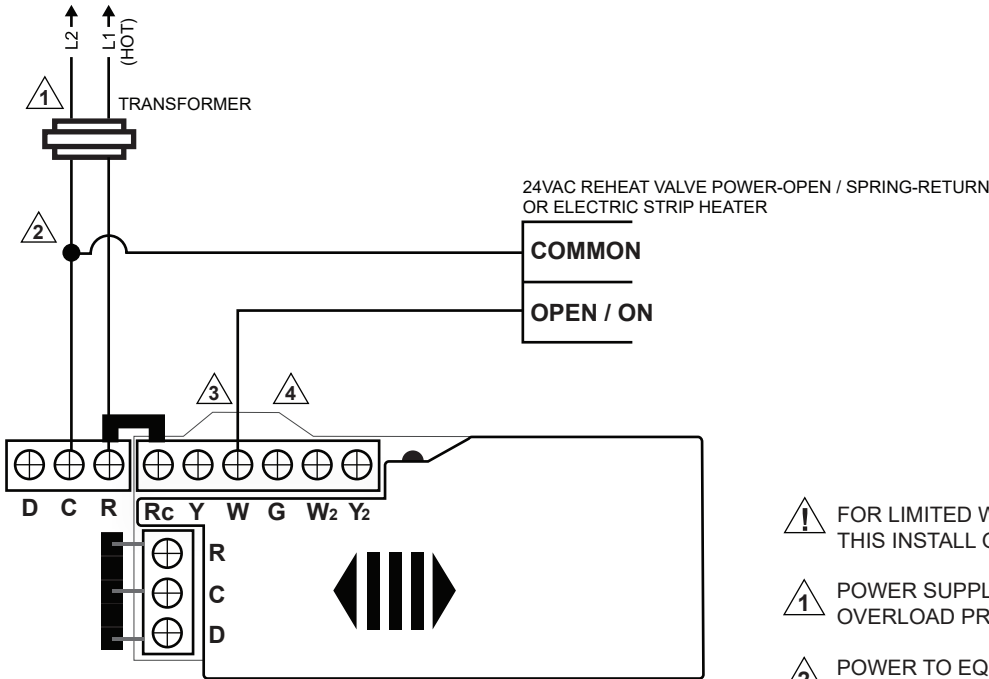
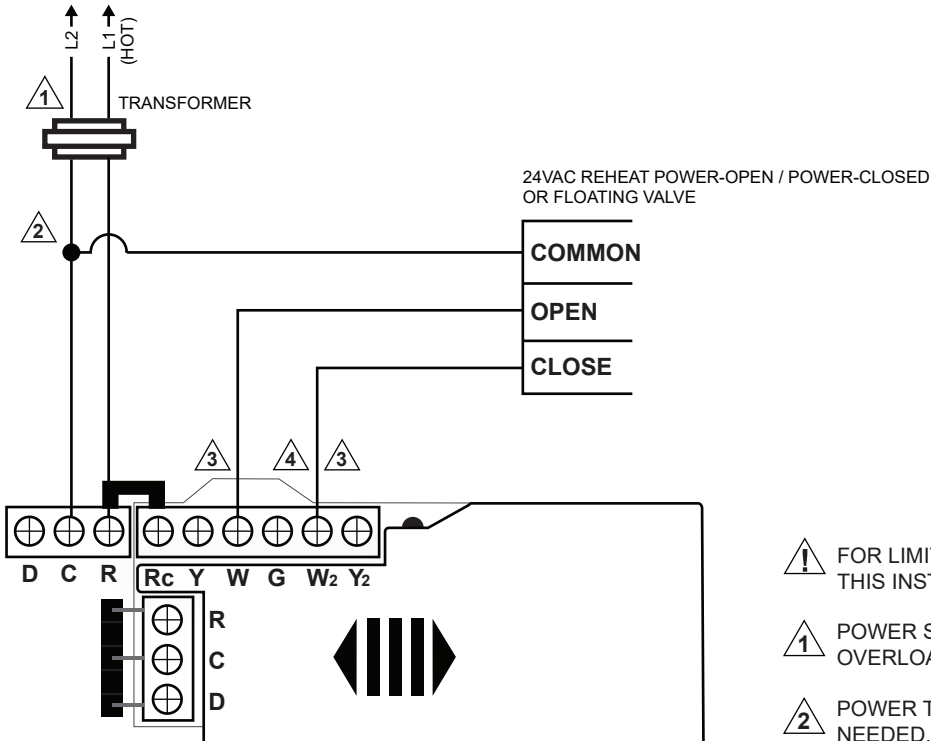

Fig. 10 – Reheat: ON/OFF Electric or Power-Open / Spring-Return Valve Motor



- FOR LIMITED WIRE INSTALLATIONS REFERENCE PAGE 10 OF THIS INSTALL GUIDE.
- POWER SUPPLY. PROVIDE DISCONNECT MEANS AND OVERLOAD PROTECTION AS REQUIRED.
- POWER TO EQUIPMENT 24VAC. SIZE TRANSFORMERS AS NEEDED.
- OUTPUT IS 24VAC @ 1A. PROVIDE PROPERLY SIZED RELAYS AS NEEDED.

Fig. 11 – Reheat: Power-Open / Power-Closed or Floating Valve Motor



- FOR LIMITED WIRE INSTALLATIONS REFERENCE PAGE 10 OF THIS INSTALL GUIDE.
- POWER SUPPLY. PROVIDE DISCONNECT MEANS AND OVERLOAD PROTECTION AS REQUIRED.
- POWER TO EQUIPMENT 24VAC. SIZE TRANSFORMERS AS NEEDED.
- OUTPUT IS 24VAC @ 1A. PROVIDE PROPERLY SIZED RELAYS AS NEEDED.



Wireless Damper Control and Remote Thermostat

WHEN INSTALLING THIS PRODUCT...

1. Read these instructions carefully and thoroughly. Failure to follow these instructions or a result of improper installation, service, adjustments, maintenance, and/or use can result in personal injury, damage to personal property, and/or cause a hazardous and dangerous situation.
2. Check the ratings and description given in the specification of the product to make sure the product is suitable for your application
3. Installer must be trained and experienced service technician. Follow all safety codes and regulations and all local and state building codes. Read instructions thoroughly and follow any warnings or notes.
4. After installation is complete, check product operation as provided in these instructions.

CAUTION

-
1. Disconnect power supply before connecting any wiring to device to prevent electrical shock or damage to equipment.
 2. This guide is designed for certified, trained, and experienced service technicians. Failure to follow installation instructions does not alleviate installer responsibility to protect the equipment, the property, and the device it is being connected too. If at anytime if there is concern or confusion about how to install this device, immediately stop what you are doing and either contact Pelican Wireless Systems or a certified Pelican Wireless Systems distributor.
-

WARNING

-
1. This equipment is designed to communicate over radio frequency to other Pelican equipment only. If this equipment is not installed and used in accordance with the instruction manual, you may experience wireless interference. This device has been tested and complies with FCC rules and regulations.
-

LOCATION AND MOUNTING

Location

In this configuration, there are two devices that need to be mounted. The Remote Thermostat (RT1) in the conditioned space and the damper controller (TCM1) at the damper actuator.

Choose a location for the Pelican remote thermostat (RT1) where the space temperature being detected is most accurate for conditioning that zone. The remote thermostat communicates wirelessly to the damper controller (TCM1).

Choose a location for the TCM1 that is not exposed to weather, and where connections are easily accessible. The TCM1's antenna must NOT be blocked by metal (ref. Page 18, Fig. 13.2). The TCM1's antenna is designed to route and repeat the Pelican wireless mesh network.

Fig. 12.1 – Pelican 24 VAC damper actuator controller (TCM1)

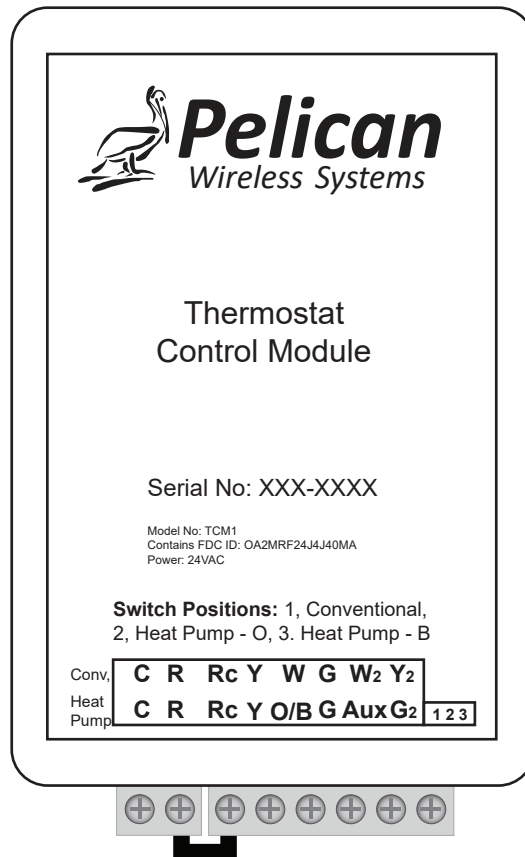

NOTE: Switch Position should be set to (1) Conventional

SINGLE DUCT

C	Common 24VAC
R	24VAC Power
Y	24VAC Damper Power Open
Y2	24VAC Damper Power Close
W	24VAC Reheat Power Open or On
W2	24VAC Reheat Power Close

DUAL DUCT

C	Common 24VAC
R	24VAC Power
Y	24VAC Cold Damper Power Open
Y2	24VAC Cold Damper Power Close
W	24VAC Heat Damper Power Open
W2	24VAC Heat Damper Power Close

Fig. 13.1 – Pelican TCM1 Mounting

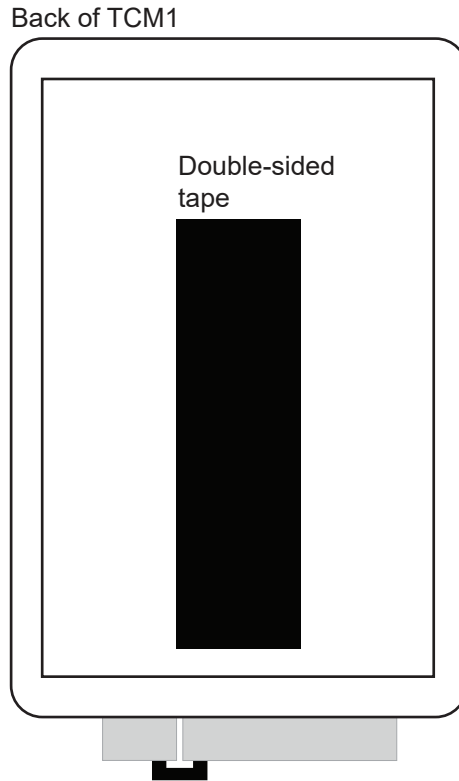

Mounting

The TCM1 is mounted on a clean, dry, flat surface with double sided tape. Make sure surface has been cleaned of all dust before applying tape.

Fig. 13.2 – TCM1 Mounting on Flat Surfaces

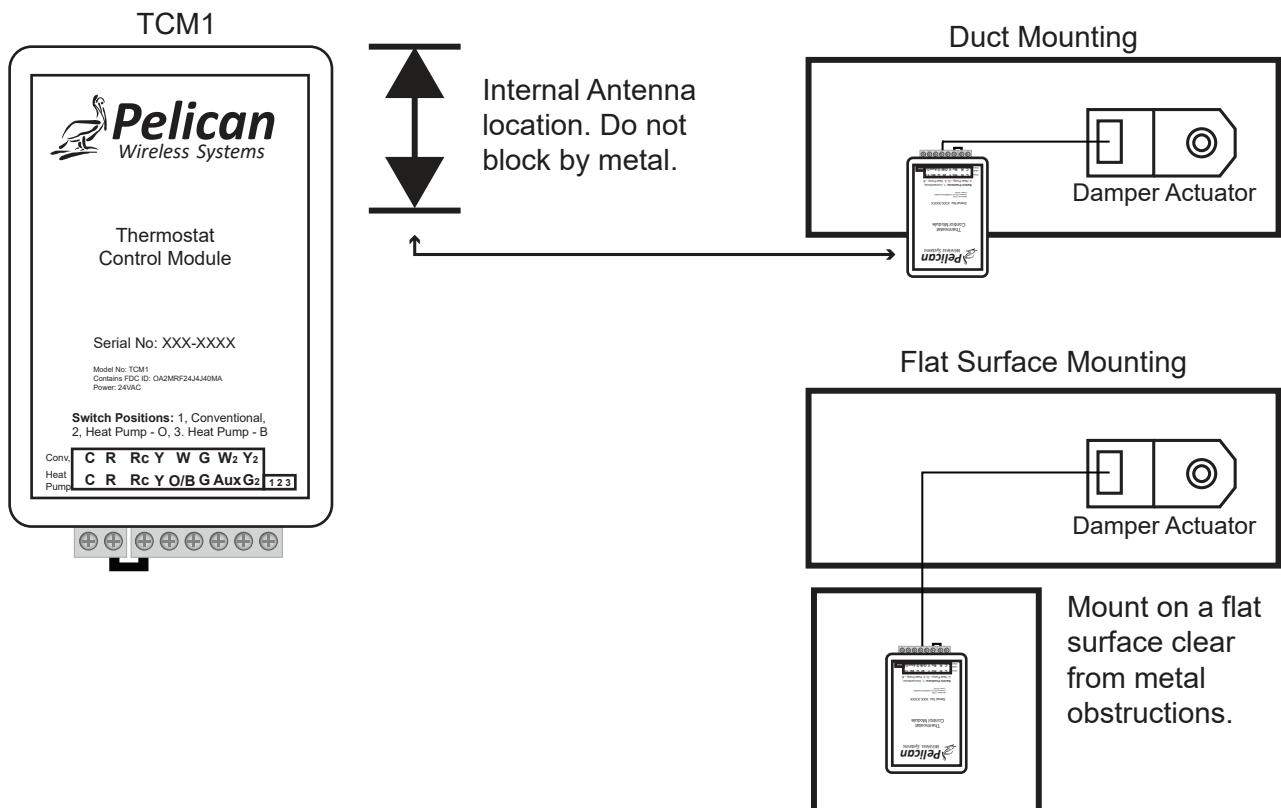
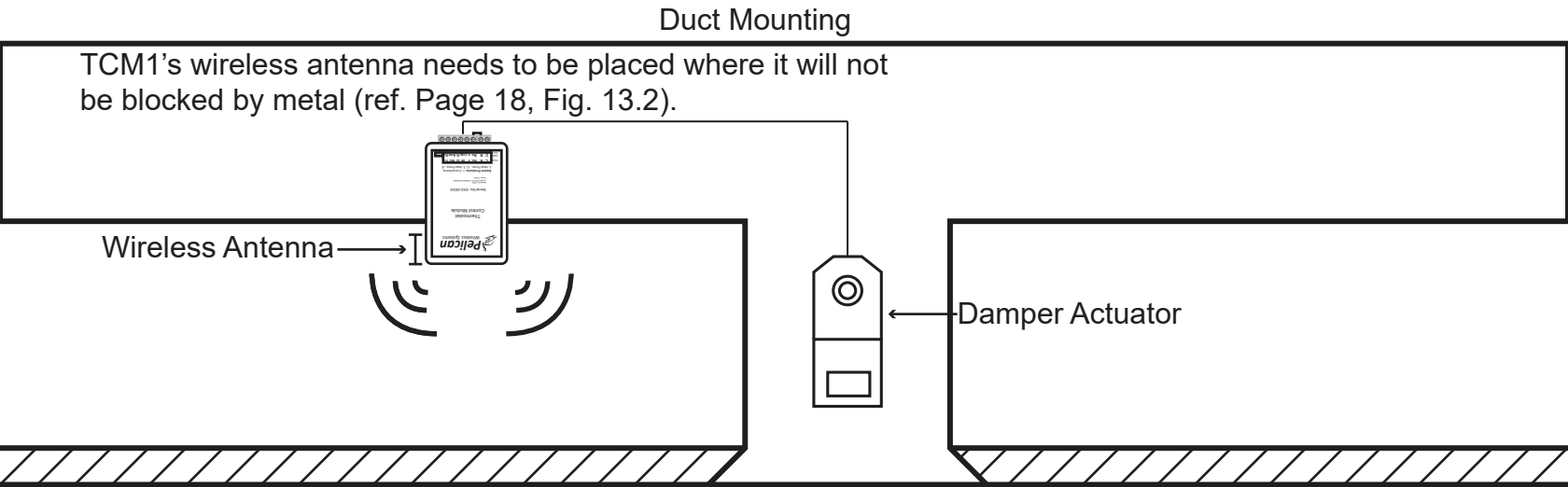

Fig. 14.3 – TCM1 to RT1 Communication Diagram



RT1-DC: Powered by 2 AA batteries installed in the conditioned space

OR



RT1-AC: Powered by 24VAC installed in the conditioned space

INSTALLATION

1. Clean surface TCM1 will be mounted on.
2. Apply strip of double sided tape to back of TCM1. Stick the TCM1 to clean flat surface with being sure that TCM1 antenna is NOT blocked by metal.
3. TCM1 wiring and hookup diagrams are shown in the TCM1 Operation and Application section as follows:
 - a. Page 21 - Fig. 15 Single Duct: Power-Open / Spring-Return Damper Actuator
 - b. Page 21 - Fig. 16 Single Duct: Power-Closed / Spring-Return Damper Actuator
 - c. Page 22 - Fig. 17 Single Duct: Power-Open / Power- Closed or Floating Damper Actuator
 - d. Page 22 - Fig. 18 Dual Duct: Power-Open / Spring-Return Damper Actuators
 - e. Page 23 - Fig. 19 Dual Duct: Power-Closed / Spring-Return Damper Actuators
 - f. Page 23 - Fig. 20 Dual Duct: Power-Open / Power-Closed or Floating Damper Actuators
 - g. Page 24 - Fig. 21 Reheat: ON/OFF Electric or Power-Open / Spring-Return Valve Motor
 - h. Page 24 - Fig. 22 Reheat: Power-Open / Power-Closed or Floating Valve Motor
4. Install RT1 thermostat in conditioned space following the instructions provided with RT1 thermostat.
5. Go to Pelican Web App and configure the RT1 to communicate with its TCM1.



WARNING

The following TCM1 wiring diagrams are to be used as reference to the most common application where a Pelican TCM1 will be installed to control specific damper actuators. For dual ducted applications, a single Pelican TCM1 will control both the hot and cold damper actuators for the zone. In the case the system you are connecting the Pelican TCM1to is not defined in this installation guide. Contact Pelican Technical Support for assistance at 888-512-0490 or email support@pelicanwireless.com.



TCM1 Detail Wiring Diagrams

Fig. 15 – Single Duct: Power-Open / Spring-Return Damper Actuator

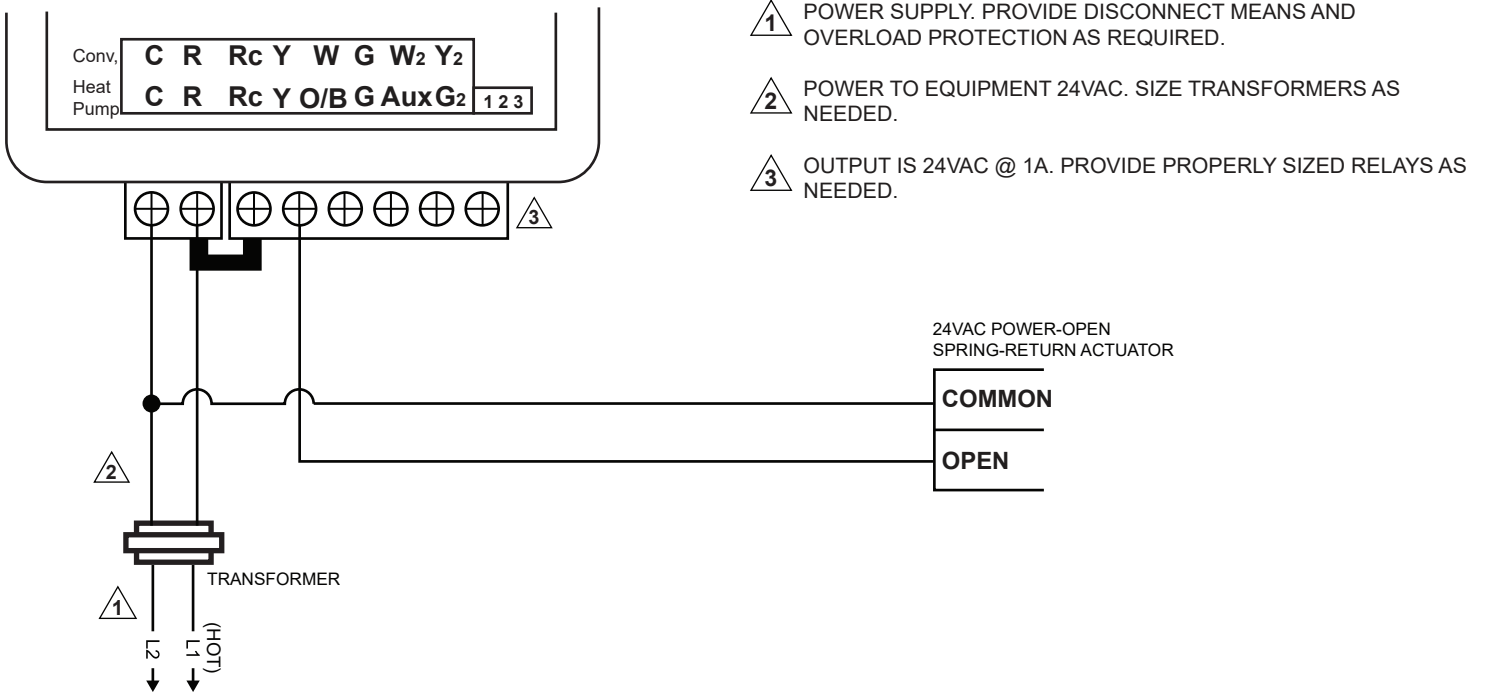

Fig. 16 – Single Duct: Power-Closed / Spring-Return Damper Actuator

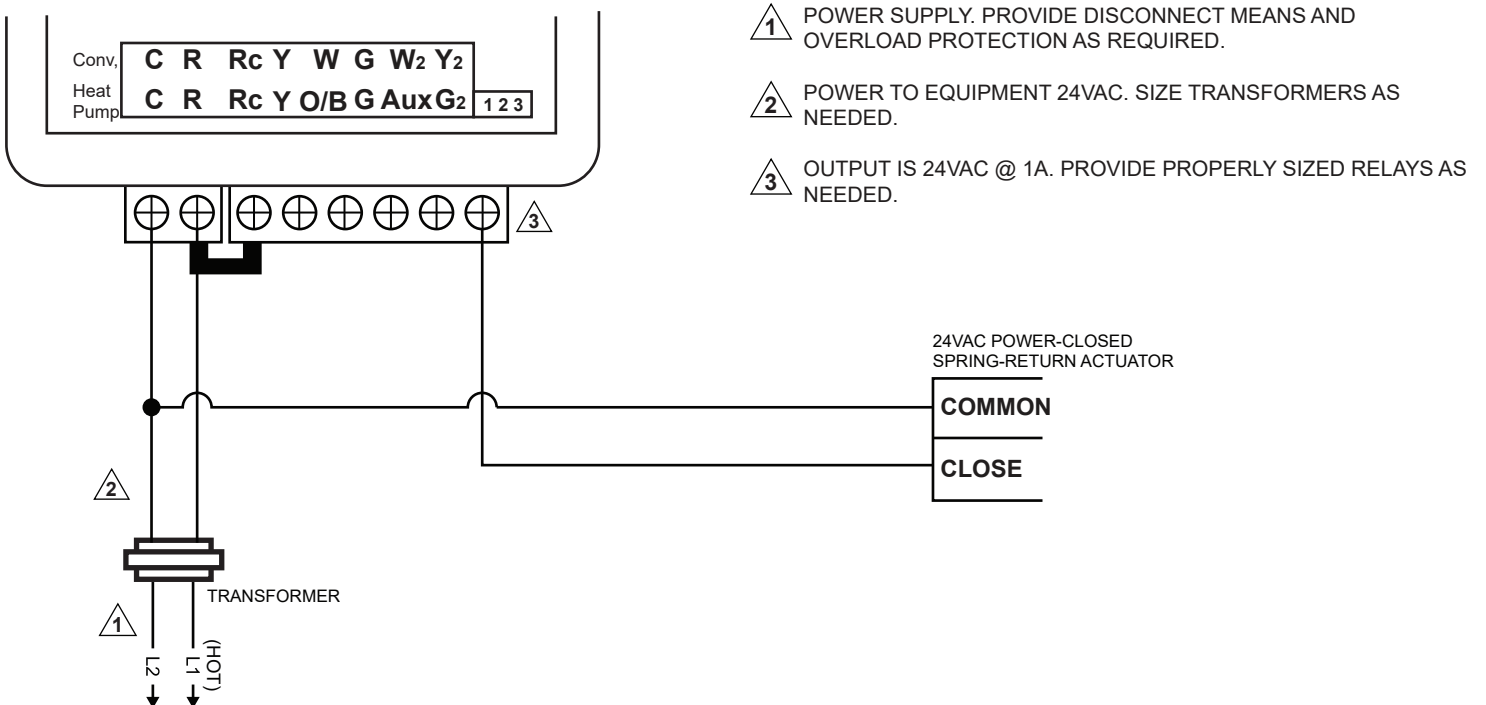

Fig. 17 – Single Duct: Power-Open / Power-Closed or Floating Damper Actuator

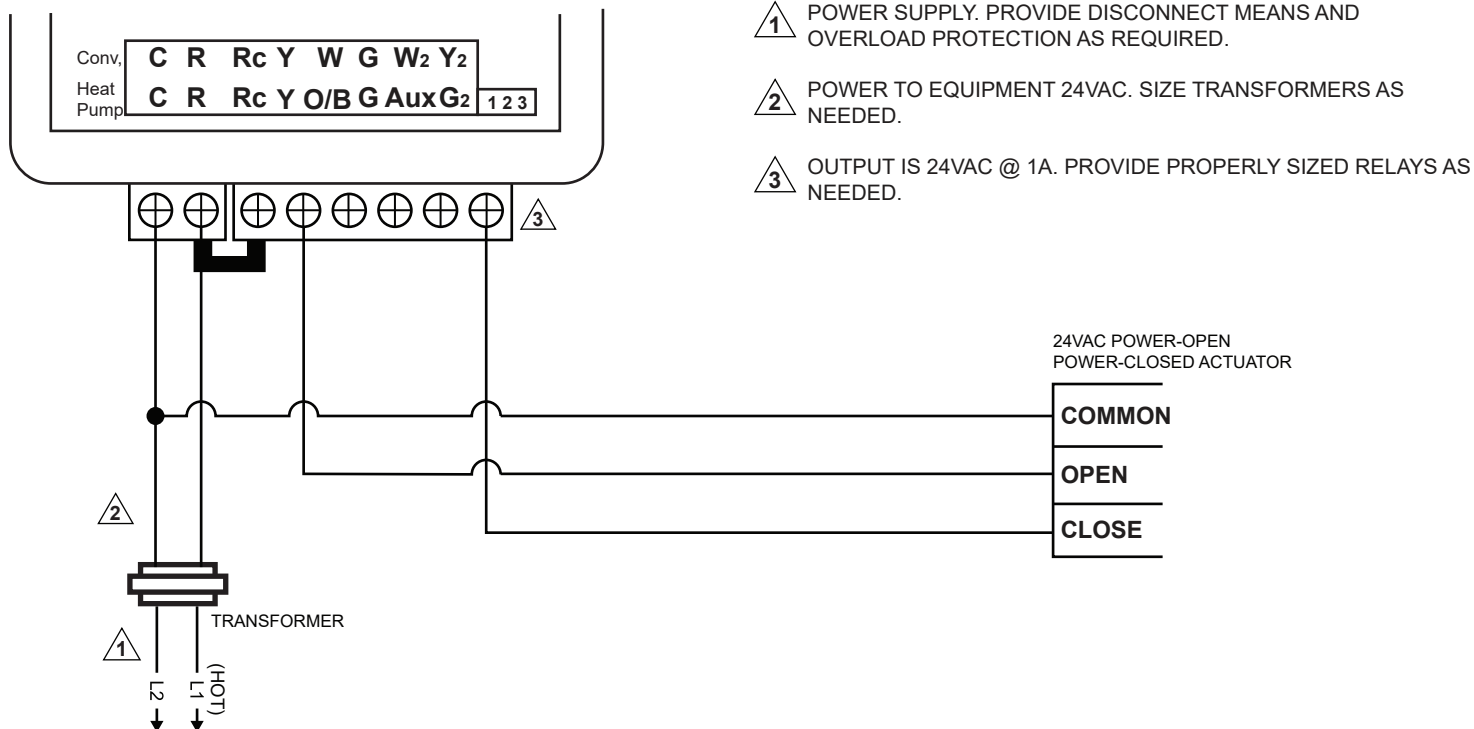

Fig. 18 – Dual Duct: Power-Open / Spring-Return Damper Actuators

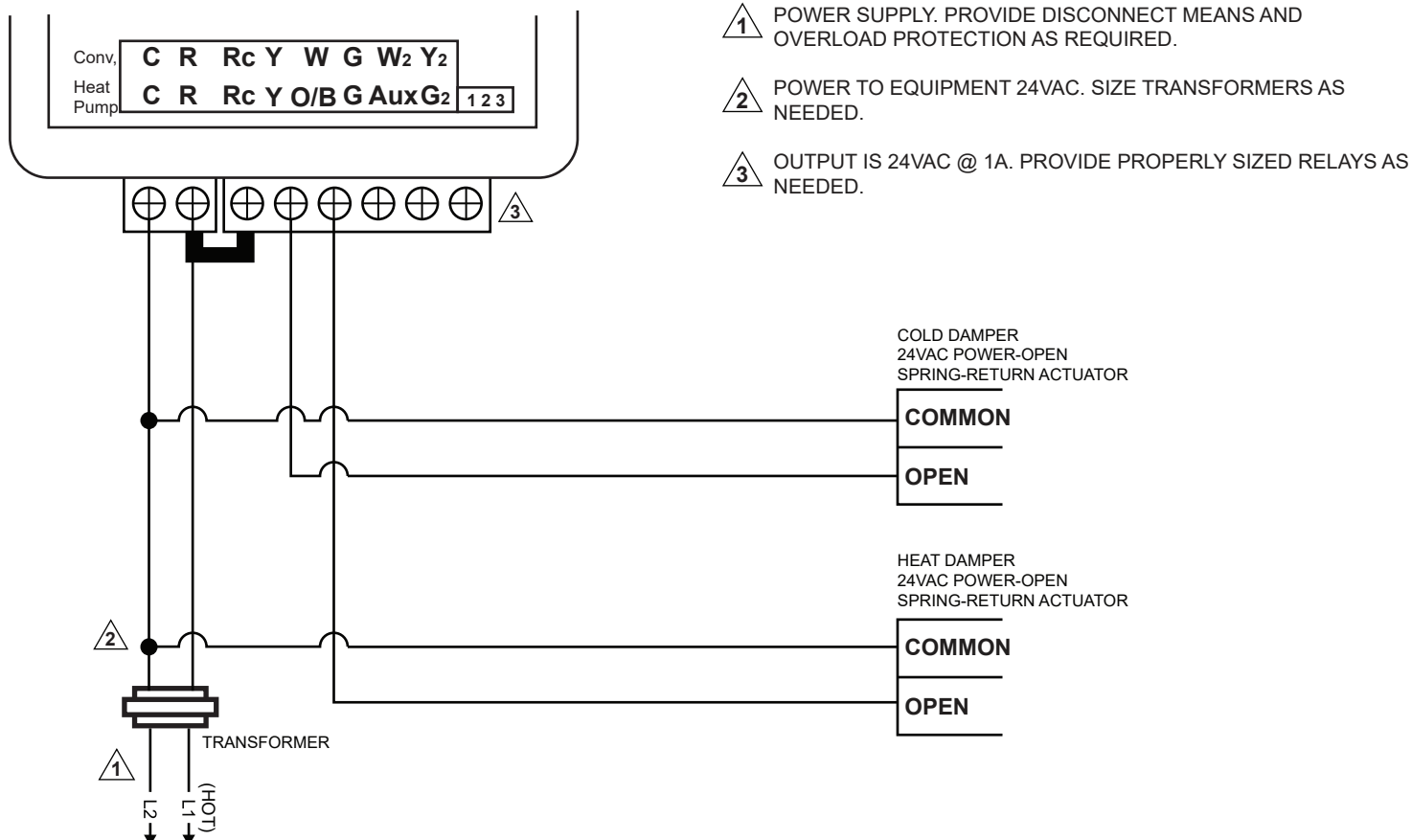
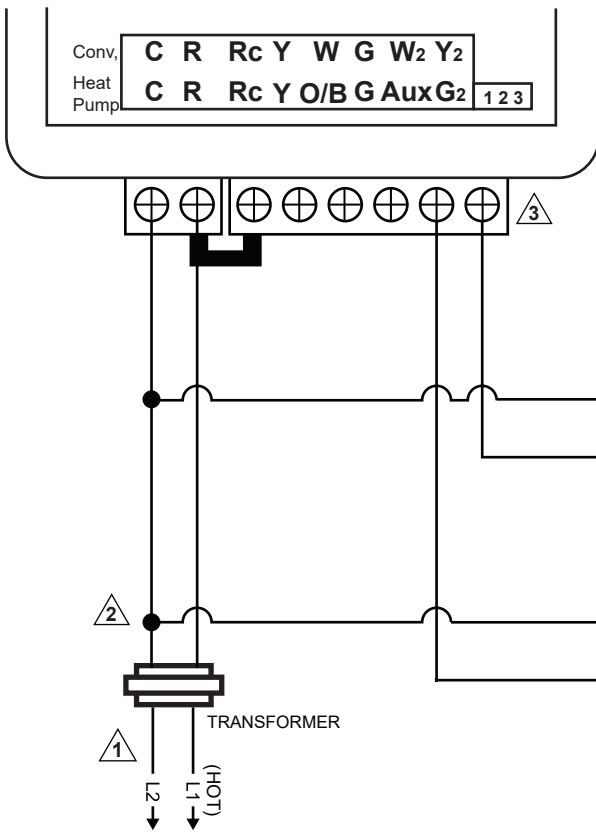
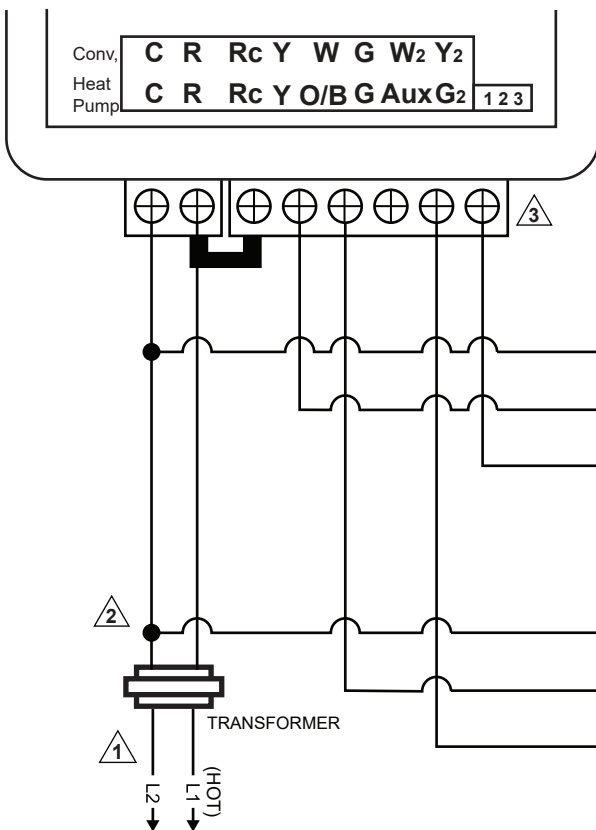

Fig. 19 – Dual Duct: Power-Closed / Spring-Return Damper Actuators



- 1 POWER SUPPLY. PROVIDE DISCONNECT MEANS AND OVERLOAD PROTECTION AS REQUIRED.
- 2 POWER TO EQUIPMENT 24VAC. SIZE TRANSFORMERS AS NEEDED.
- 3 OUTPUT IS 24VAC @ 1A. PROVIDE PROPERLY SIZED RELAYS AS NEEDED.

Fig. 20 – Dual Duct: Power-Open / Power-Closed or Floating Damper Actuators



- 1 POWER SUPPLY. PROVIDE DISCONNECT MEANS AND OVERLOAD PROTECTION AS REQUIRED.
- 2 POWER TO EQUIPMENT 24VAC. SIZE TRANSFORMERS AS NEEDED.
- 3 OUTPUT IS 24VAC @ 1A. PROVIDE PROPERLY SIZED RELAYS AS NEEDED.

Fig. 21 – Reheat: ON/OFF Electric or Power-Open / Spring-Return Valve Motor

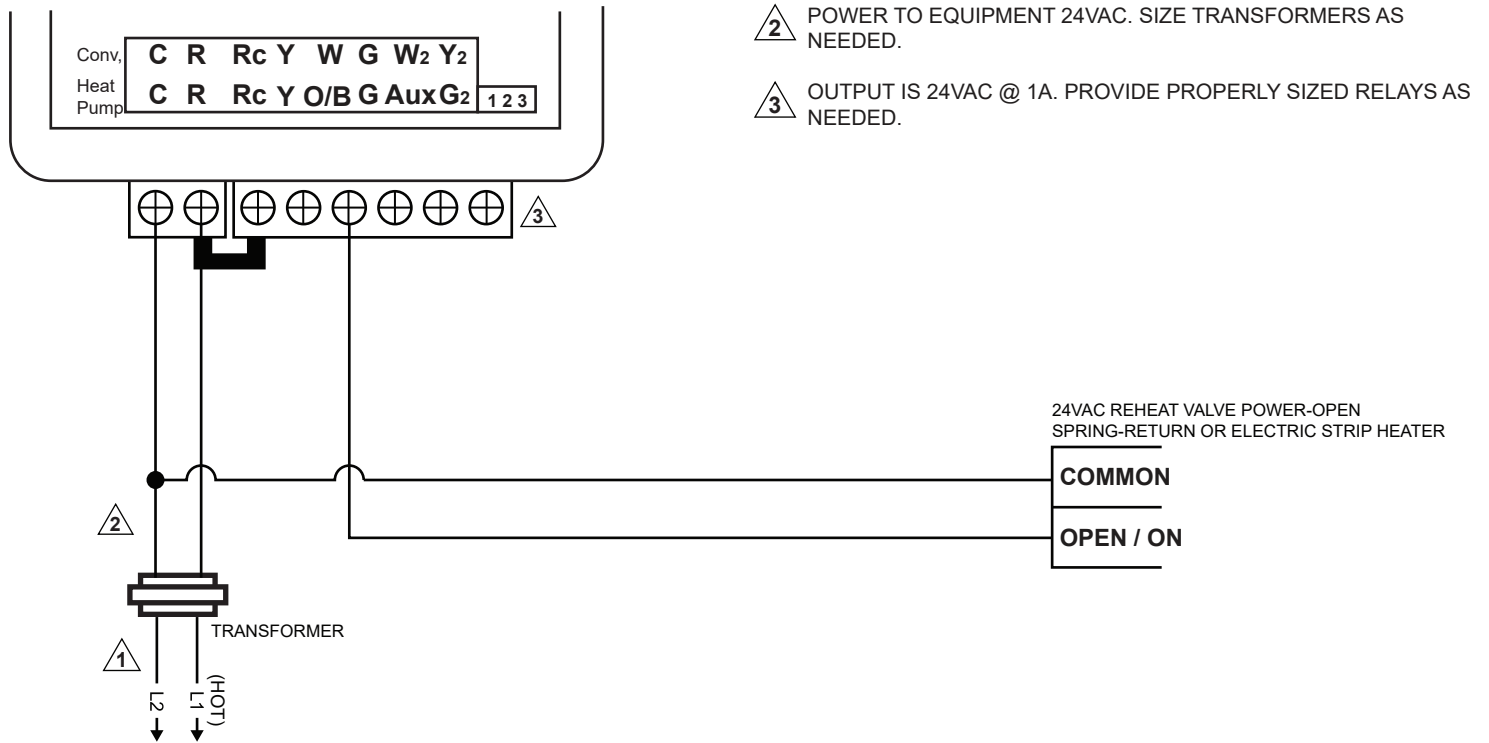

- 1 POWER SUPPLY. PROVIDE DISCONNECT MEANS AND OVERLOAD PROTECTION AS REQUIRED.
- 2 POWER TO EQUIPMENT 24VAC. SIZE TRANSFORMERS AS NEEDED.
- 3 OUTPUT IS 24VAC @ 1A. PROVIDE PROPERLY SIZED RELAYS AS NEEDED.

Fig. 22 – Reheat: Power-Open / Power-Closed or Floating Valve Motor

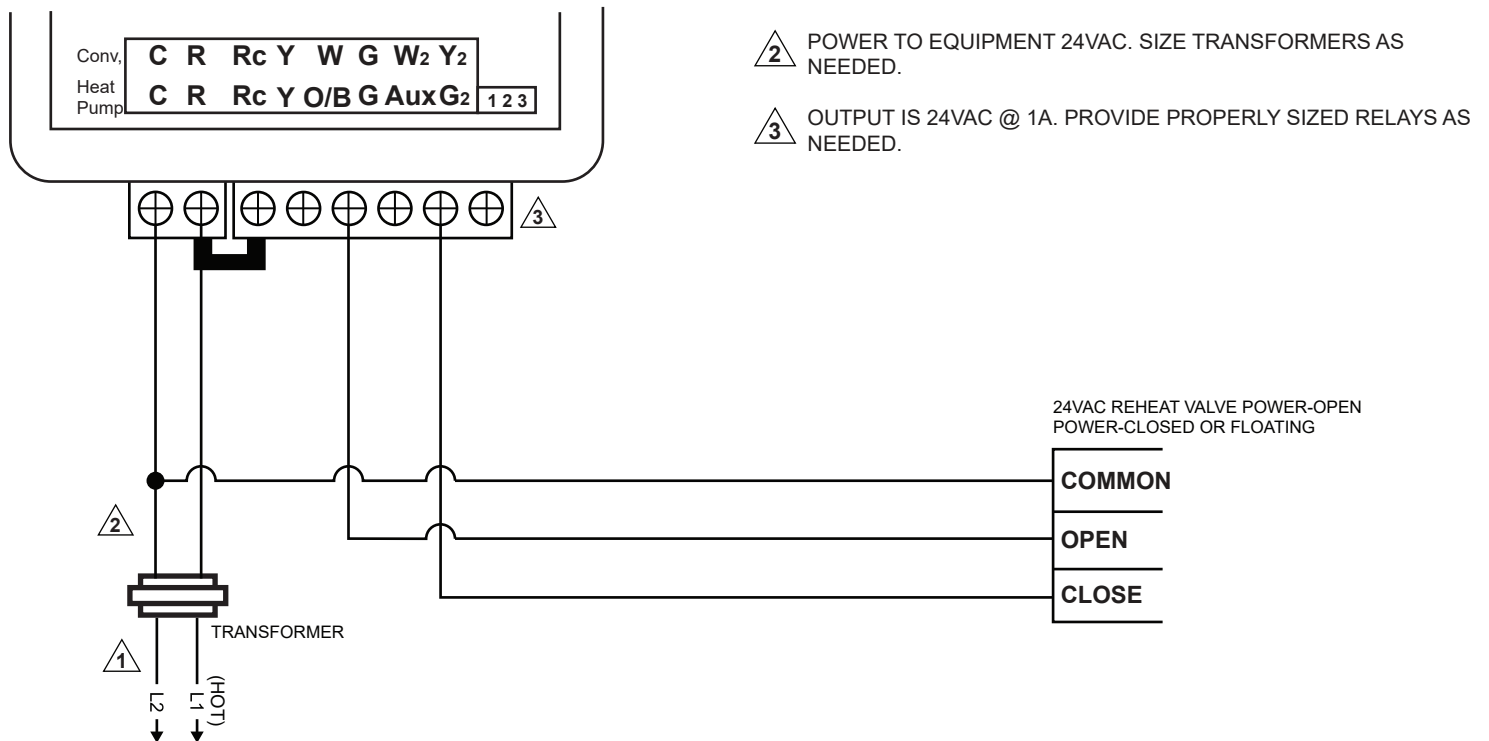

- 1 POWER SUPPLY. PROVIDE DISCONNECT MEANS AND OVERLOAD PROTECTION AS REQUIRED.
- 2 POWER TO EQUIPMENT 24VAC. SIZE TRANSFORMERS AS NEEDED.
- 3 OUTPUT IS 24VAC @ 1A. PROVIDE PROPERLY SIZED RELAYS AS NEEDED.

Configuration

1 PELICAN WEB APP

To configure a new Pelican Zone Thermostat or Damper Controller, navigate to your Pelican Web App using any web browser (Google Chrome, Apple Safari, Microsoft Edge, etc.). All configuration is done through the Pelican Web App. If you do not already have a Pelican Web App, you will need to install a Pelican Gateway (GW400) at the same location. For further information on the Pelican Gateway (GW400) visit www.PelicanWireless.com.

2 SERIAL NUMBER

Each Pelican Thermostat has a unique identification serial number. This serial number is found on the bottom and behind the front cover of a Thermostat or on the front of the TCM1. With the Serial Number(s) recorded, log onto your Pelican Web App to find new notification(s) matching the zone(s) serial number(s). Press configure next to the device you are configuring.

If no new notifications are found, select 'Admin' and identify if the new Thermostat or TCM1 is found on your Pelican Web App. If are are unable to find the Thermostat or TCM1 under Admin, then the Thermostat or TCM1 is unable to communicate with the wireless gateway. Go to Page 22 for Troubleshooting.

3 SYSTEM CONFIGURATION OPTIONS

The following flow chart illustrates Thermostat and TCM1 configuration options.

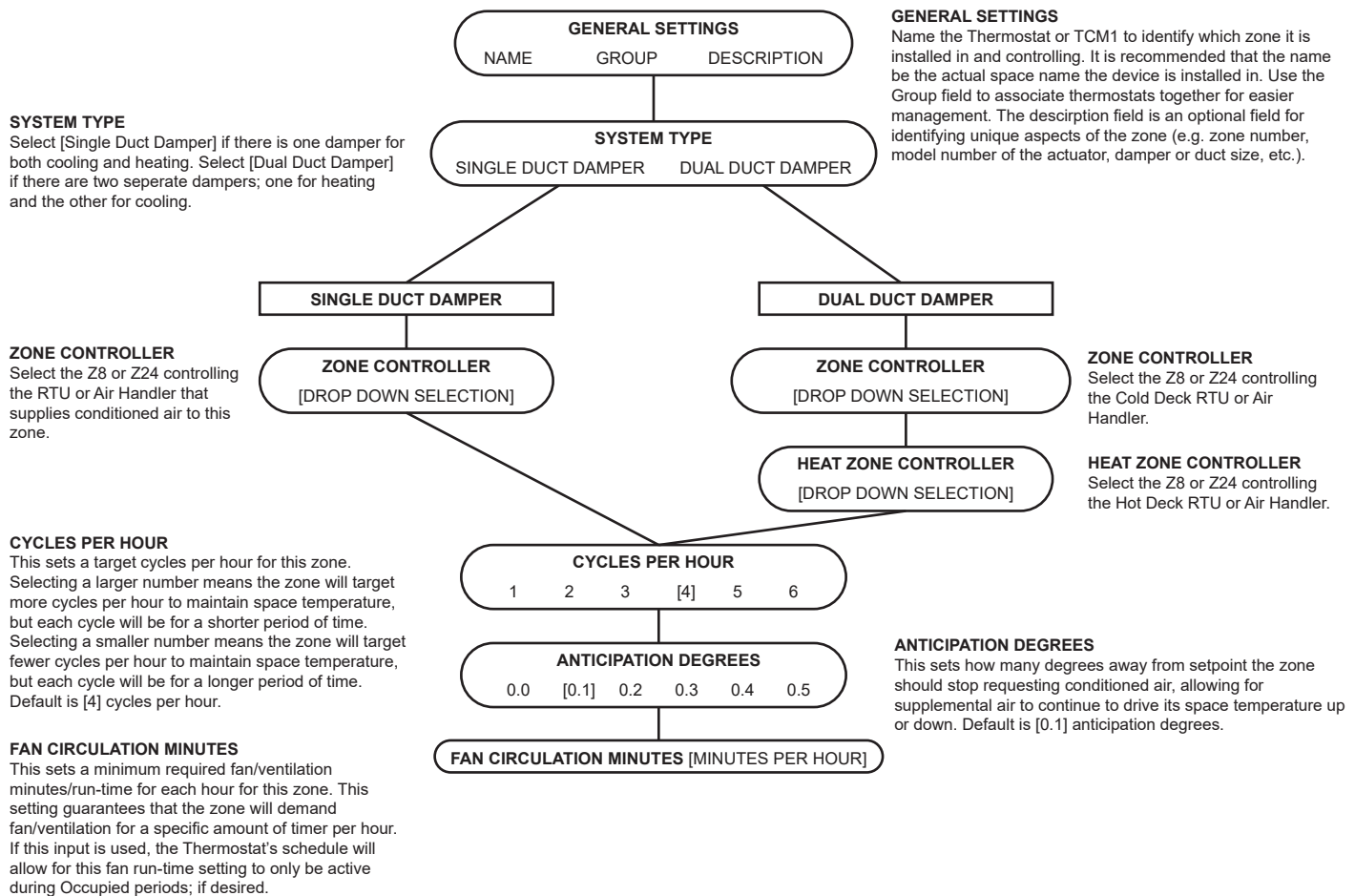

4

DAMPER CONFIGURATION OPTIONS

The following flow chart illustrates Thermostat and TCM1 damper configuration options.

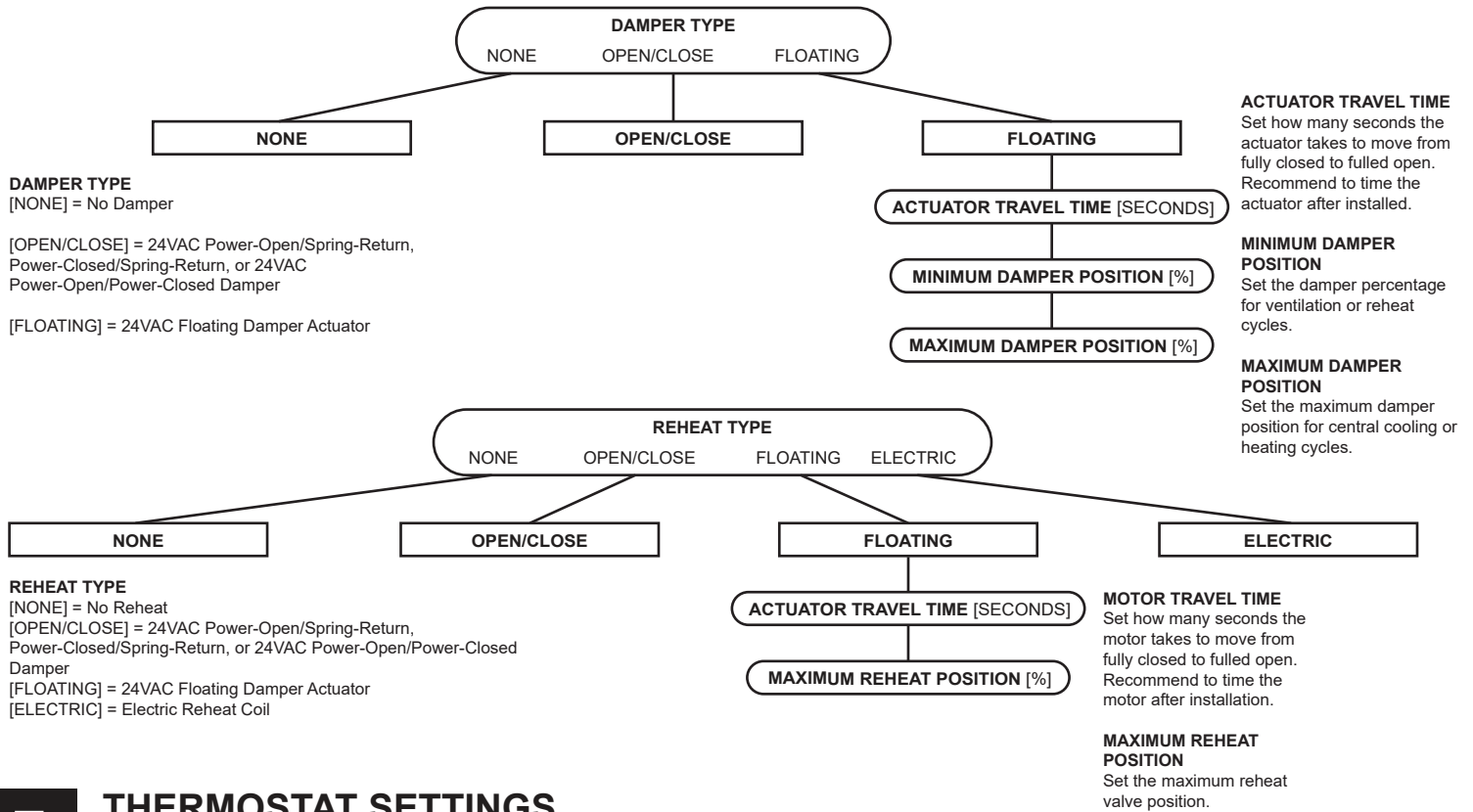

5

THERMOSTAT SETTINGS

The following flow chart illustrates Thermostat configuration options.

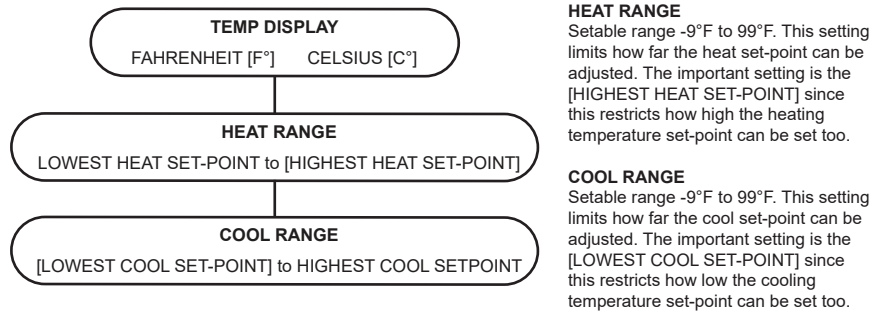

6

NOTIFICATION SETTINGS

The following flow chart illustrates notification configuration options.

OFF
Disables automated notifications (does not disable Safe Range notifications).

LOW
If the thermostat is actively trying to condition the space, and the space temp is not moving towards or is moving away from the temp set-point, with the space temp being at least 5°F from the temp set-point for one hour, a notification will be generated.

MEDIUM
If the thermostat is actively trying to condition the space, and the space temp is not moving towards or is moving away from the temp set-point, with the space temp being at least 1°F from the temp set-point for one hour, a notification will be generated.

HIGH
Is the same as Medium, but add an automatic notification if the thermostat becomes unreachable.

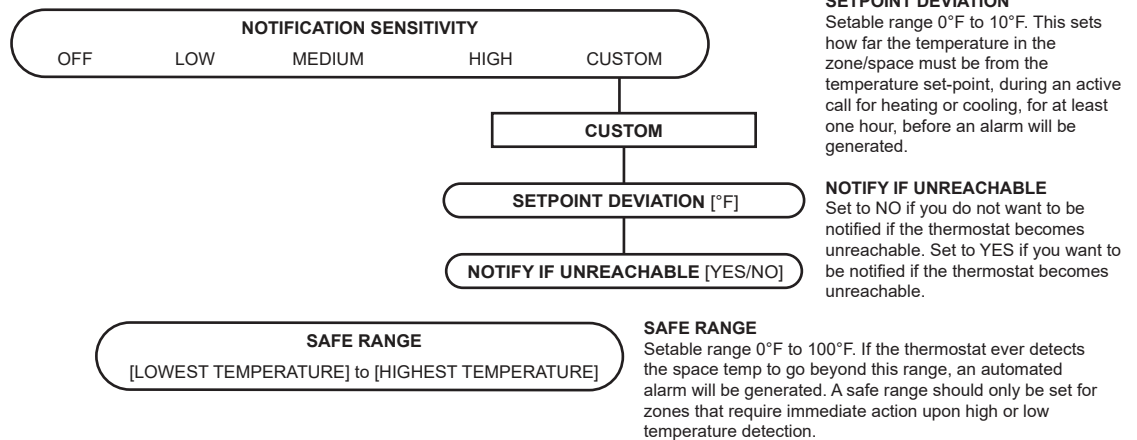

THIS PAGE
INTENTIONALLY
LEFT BLANK



Pelican

Wireless Systems

2655 Collier Canyon Road
Livermore, CA 94550

Phone: 888-512-0490

eMail: sales@pelicanwireless.com
support@pelicanwireless.com

Web: www.pelicanwireless.com

37-0003 Version 2
© All Rights Reserved. Pelican Wireless Systems, LLC.